



ALL IN ONE ESS

Low Voltage

AI-W5.1-3.6P1-EU-ESS

AI-W5.1-5P1-EU-ESS

AI-W5.1-6P1-EU-ESS

AI-W5.1-7.6P1-EU-ESS

AI-W5.1-8P1-EU-ESS

User Manual



Contents

1. Safety Introductions	01
2. Product instructions	02-04
2.1 Product Overview	
2.2 Product Size	
2.3 Product Features	
2.4 Basic System Architecture	
2.5 Product handling requirements	
3. Installation	04-23
3.1 Parts list	
3.2 Mounting instructions	
3.3 Battery connection	
3.4 Grid connection and backup load connection	
3.5 PV Connection	
3.6 CT Connection	
3.6.1 Meter Connection	
3.7 Earth Connection(mandatory)	
3.8 WIFI Connection	
3.9 Wiring System for Inverter	
3.10 Typical application diagram of diesel generator	
3.11 Single phase parallel connection diagram	
3.12 Three phase Parallel Inverter	
4. OPERATION	24
4.1 Power ON/OFF	
4.2 Operation and Display Panel	
5. LCD Display Icons	25-37
5.1 Main Screen	
5.2 Solar Power Curve	
5.3 Curve Page-Solar & Load & Grid	
5.4 System Setup Menu	
5.5 Basic Setup Menu	
5.6 Battery Setup Menu	
5.7 System Work Mode Setup Menu	
5.8 Grid Setup Menu	
5.9 Generator Port Use Setup Menu	
5.10 Advanced Function Setup Menu	
5.11 Device Info Setup Menu	
6. Mode	37-39
7. Fault information and processing	39-42
8. Limitation of Liability	42
9. Datasheet	43-44
10. Appendix I	45-47
11. Appendix II	48

	<i>Model</i>
Inverter	AI-W5.1-3.6/5/6/7.6/8P1-EU
Battery System	AI-W5.1

About This Manual

The manual mainly describes the product information, guidelines for installation, operation and maintenance. The manual cannot include complete information about the photovoltaic (PV) system.

How to Use This Manual

Read the manual and other related documents before performing any operation on the inverter. Documents must be stored carefully and be available at all times.

Contents may be periodically updated or revised due to product development. The information in this manual is subject to change without notice. The latest manual can be acquired via sales@voltha.net

1. Safety Introductions

Safety signs



The DC input terminals of the inverter must not be grounded.



Surface high temperature, Please do not touch the inverter case.



5min

The AC and DC circuits must be disconnected separately, and the maintenance personnel must wait for 5 minutes before they are completely powered off before they can start working.



Prohibit disassembling inverter case, there existing shock hazard, which may cause serious injury or death, please ask qualified person to repair.



Please read the instructions carefully before use.



Do Not put it in the waste bin! Recycle it by licensed professional!

- This chapter contains important safety and operating instructions. Read and keep this manual for future reference.
- Before using the inverter, please read the instructions and warning signs of the battery and corresponding sections in the instruction manual.
- Do not disassemble the inverter. If you need maintenance or repair, take it to a professional service center.
- Improper reassembly may result in electric shock or fire.
- To reduce risk of electric shock, disconnect all wires before attempting any maintenance or cleaning. Turning off the unit will not reduce this risk.
- Caution: Only qualified personnel can install this device with battery.
- Never charge a frozen battery.
- For optimum operation of this inverter, please follow required specification to select appropriate cable size. It is very important to correctly operate this inverter.
- Be very cautious when working with metal tools on or around batteries. Dropping a tool may cause a spark or short circuit in batteries or other electrical parts, even cause an explosion.
- Please strictly follow installation procedure when you want to disconnect AC or DC terminals. Please refer to "Installation" section of this manual for the details.
- Grounding instructions - this inverter should be connected to a permanent grounded wiring system. Be sure to comply with local requirements and regulation to install this inverter.
- Never cause AC output and DC input short circuited. Do not connect to the mains when DC input short circuits.

2. Product Introductions

This is an All-in-one energy storage system, integrated 3.6kW~8kW hybrid inverters and energy storage batteries. Modular stacked design, easy installation, easy expansion, capacity range of 5kWh to 30kWh. Lithium iron phosphate battery, safe and reliable.

This is a multifunctional inverter, combining functions of inverter, solar charger and battery charger to offer uninterruptible power support with portable size. Its comprehensive LCD display offers user configurable and easy accessible button operation such as battery charging, AC/solar charging, and acceptable input voltage based on different applications.

2.1 Product Overview

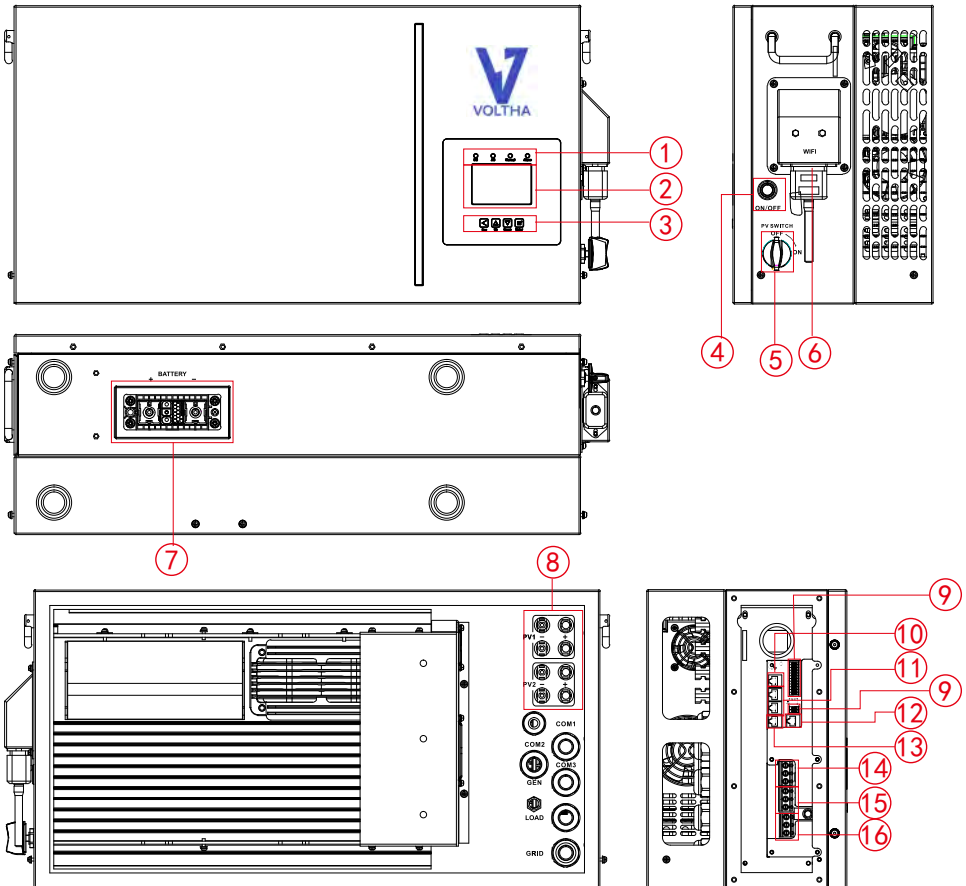

1: Inverter indicators

2: LCD display

3: Function buttons

4: Power on/off button

5: DC switch

6: WiFi Interface

7: Battery input connectors

8: PV input with two MPPT

9: Function port

10: RS485/METER port

11: Parallel port

12: BMS 485/CAN port

13: DRM port

14: Generator port

15: Load port

16: Grid port

2.2 Product Size

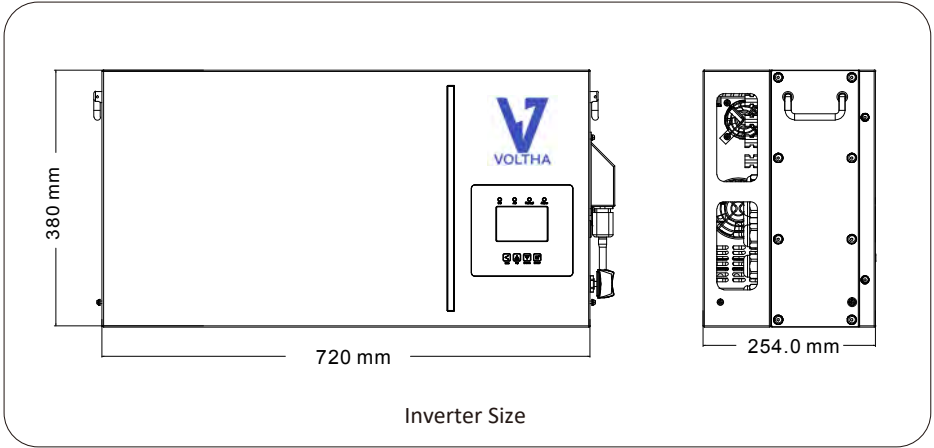

2.3 Product Features

- Self-consumption and feed-in to the grid.
- Auto restart while AC is recovering.
- Programmable supply priority for battery or grid.
- Programmable multiple operation modes: On grid, off grid and UPS.
- Configurable battery charging current/voltage based on applications by LCD setting.
- Configurable AC/Solar/Generator Charger priority by LCD setting.
- Compatible with mains voltage or generator power.
- Overload/over temperature/short circuit protection.
- Smart battery charger design for optimized battery performance
- With limit function, prevent excess power overflow to the grid.
- Supporting WIFI monitoring and build-in 2 strings of MPP trackers
- Smart settable three stages MPPT charging for optimized battery performance.
- Time of use function.
- Smart Load Function.

2.4 Basic System Architecture

The following illustration shows basic application of this inverter. It also includes following devices to have a Complete running system.

- Generator or Utility
- PV modules

Consult with your system integrator for other possible system architectures depending on your requirements.

This inverter can power all kinds of appliances in home or office environment, including motor type appliances such as refrigerator and air conditioner.

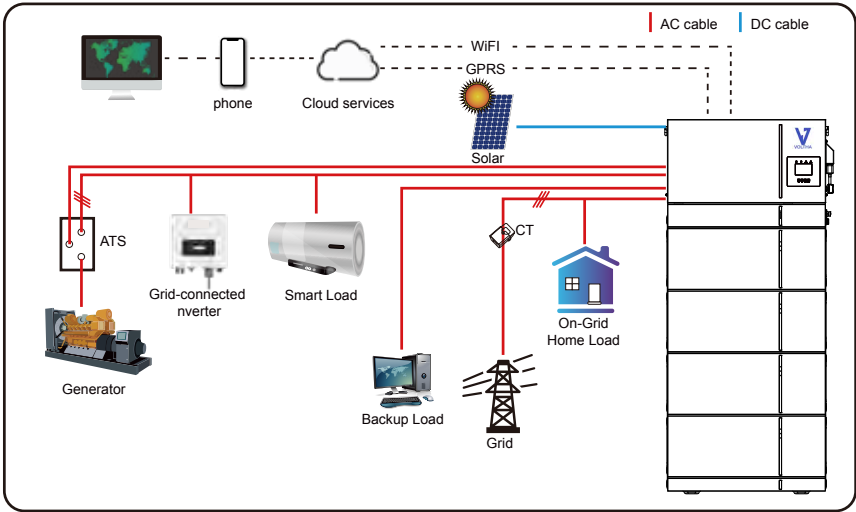

2.5 Product handling requirements

Two people stand on both sides of the machine, holding one handles to lift the machine.

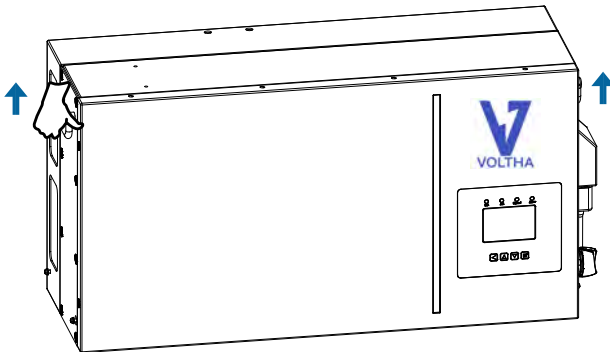

3. Installation

3.1 Parts List

Check the equipment before installation. Please make sure nothing is damaged in the package. You should have received the items in the following package:

Inverter package

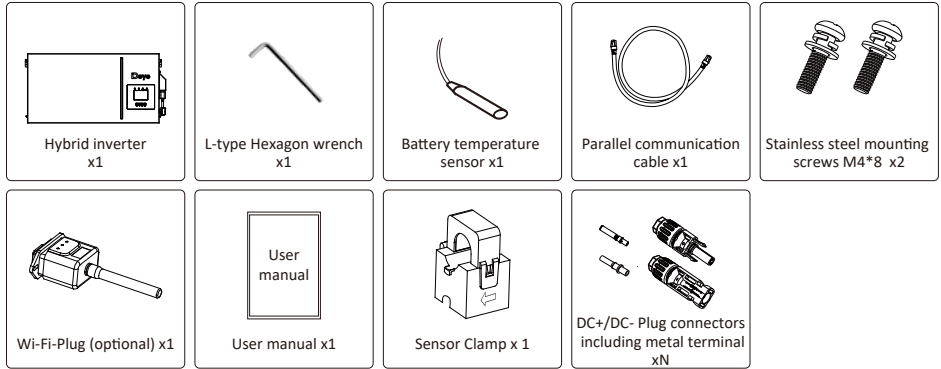

System Power Distribute Unit packaging box

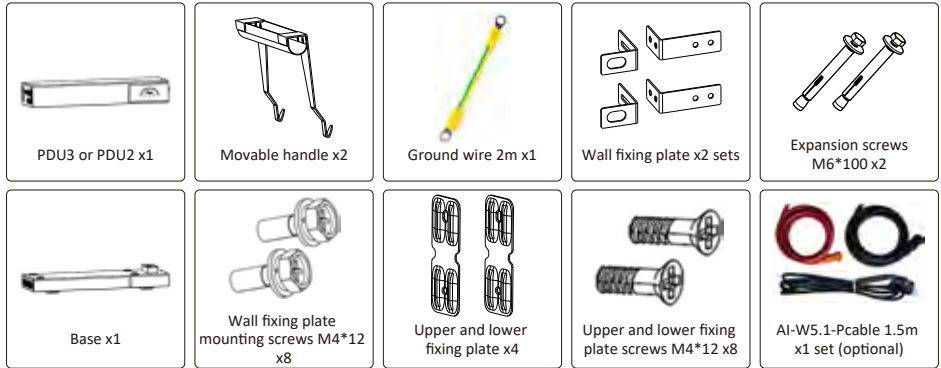

Li-ion Battery Pack packaging box

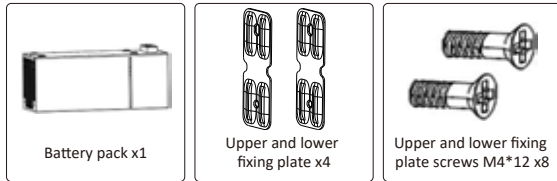

3.2 Mounting instructions

Installation Precaution

This Hybrid inverter is designed for outdoor use(IP65), Please make sure the installation site meets below conditions:

- Not in direct sunlight
- Not in areas where highly flammable materials are stored.
- Not in potential explosive areas.
- Not in the cool air directly.
- Not near the television Antenna or antenna cable.
- Not higher than altitude of about 2000 meters above sea level.
- Not in environment of precipitation or humidity(>95%)

Please AVOID direct sunlight, rain exposure, snow laying up during installation and operation. Before connecting all wires, please take off the metal cover by removing screws as shown below:

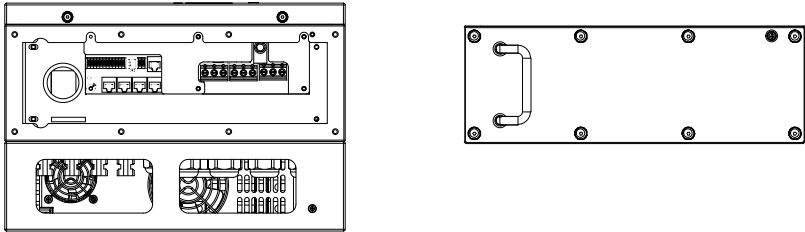

3.3 Battery connection

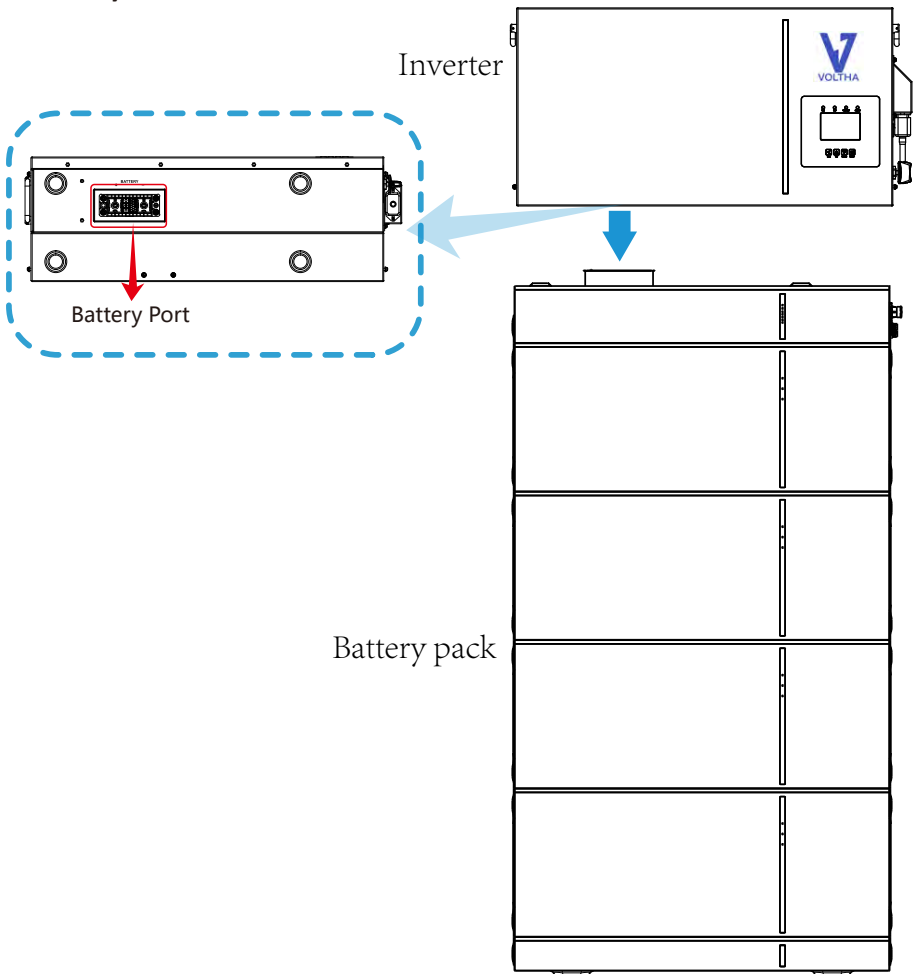

3.3.1 Install the Battery



CAUTION:

Remember that this battery is heavy! Please be careful when lifting out from the package.

The battery module must be installed by at least two persons using movable handles.

3.3.1.1 Selection of installation sites

It is necessary to choose the appropriate installation site according to the requirements of 5.1. The system must not be immersed in water. The battery base should not be placed in rain or other water sources. It is recommended that the height of the base is 300mm from the ground, and the weight of the base should be able to support the weight of the entire battery system 124kg~336kg.

The installation location is recommended to meet the size requirements of the figure below :

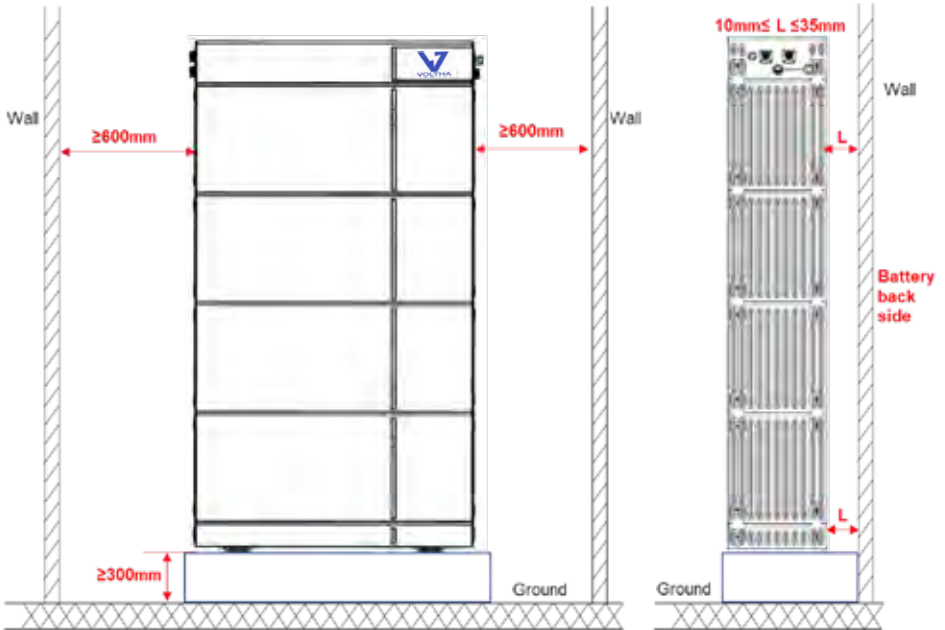

3.3.1.2 Unpacking order

First open the box of the **System Power Distribute Unit** packaging box, take out the base and handle, the handle is used to carry the battery module, without the handle the battery module will be difficult to remove from the battery box.

3.3.1.3 Installation order

i. Put the installed base and feet along the wall, and keep the distance of 10~35 mm between the wall and the base.

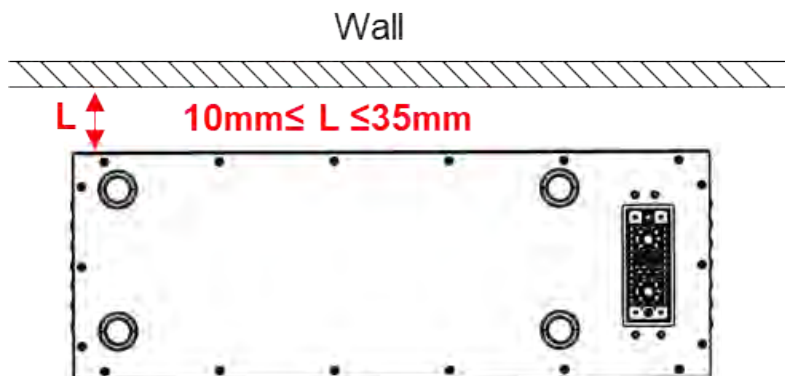

ii. Open the battery box, take a battery module from the package out. Put one battery module on the base. Pay attention to the direction of the module to make sure that the blind-mating connectors of the module and the base are at the same side.

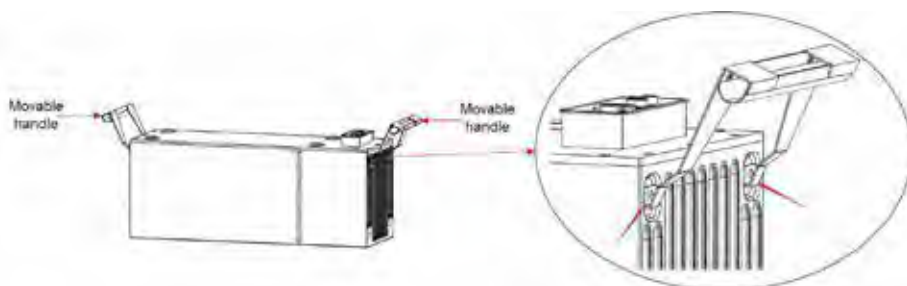

iii. Repeat the operations for other battery modules.

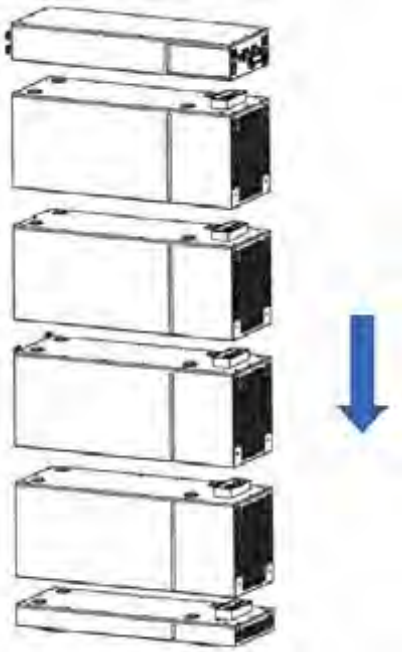

iv. Install the wall fixing plate (PDU part) to the PDU. To do this, follow the instructions below to install and tighten them on the back side of PDU (torque: 2 Nm).

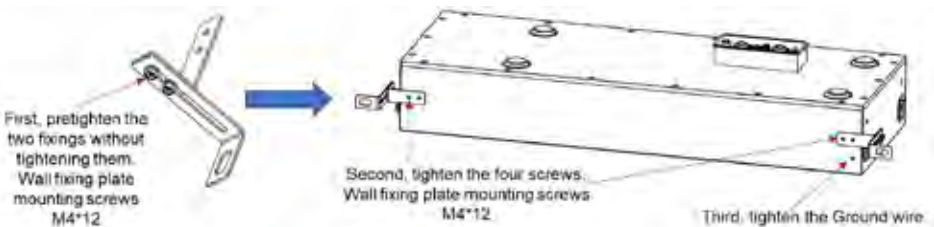

v. Put the PDU on top of the battery modules.

vi. Fix the upper and lower fixing plate connection between the battery module and the base, between battery modules, and between PDU and battery module. To do this, insert the screws (M4x12) through the holes on them, using a Hexagon Wrench (2.5mm) and tighten them (torque: 2 Nm).

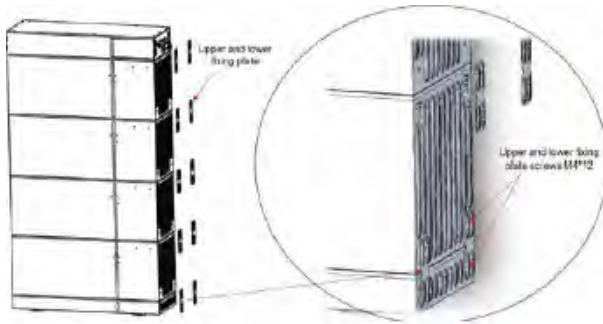

vii. Hold the wall fixing plate (wall part) where it intends to be mounted on the wall and mark the position of the drill holes. Please pay attention that there may be power cables or other supply lines (e.g., gas or water) routed inside of the wall. Ensure that no lines are laid in the wall, which could be damaged when drilling holes.

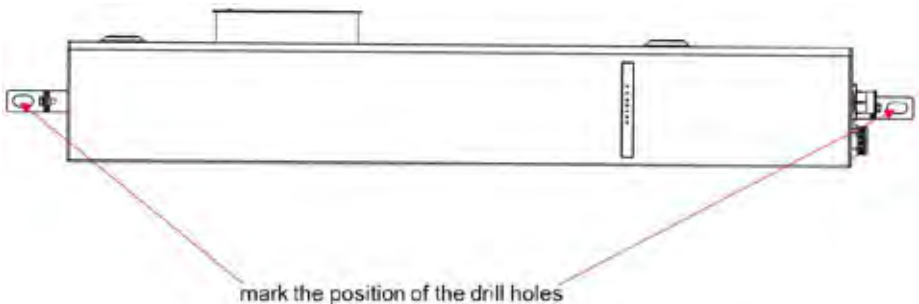

viii. Set the wall fixing plate (wall part) aside and drill the marked holes. Choose the recommend drill head (10mm) to drill 2 holes on the wall,100mm-110mm deep. Put the wall fixing plate (wall part) in front of the holes, then insert the expansion screw of M6*100 and tighten.

ix. Fix the two hangers (wall part and PDU part) with M4X12 screws, using a cylinder screwdriver (10 mm) to tighten it (torque: 2 Nm).

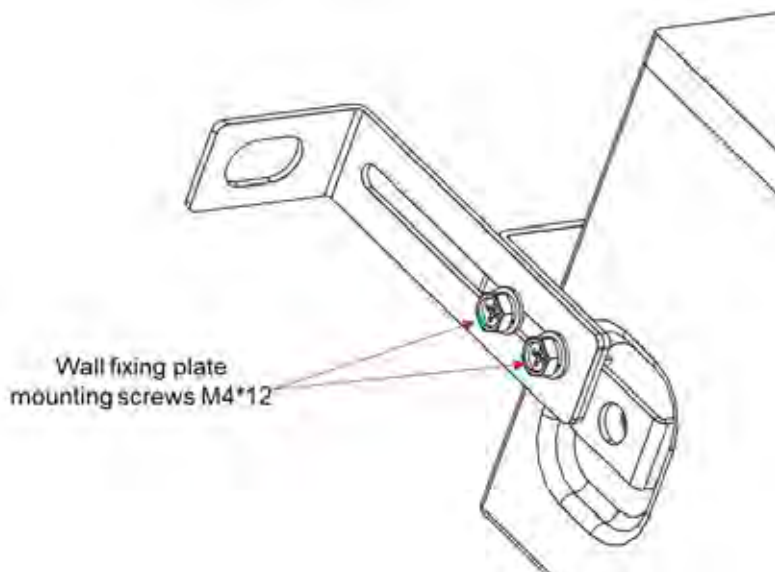

3.3.2 Function port definition

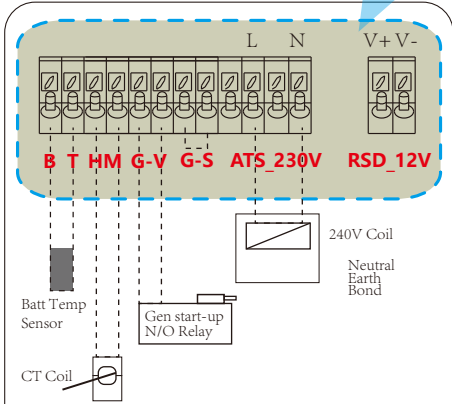
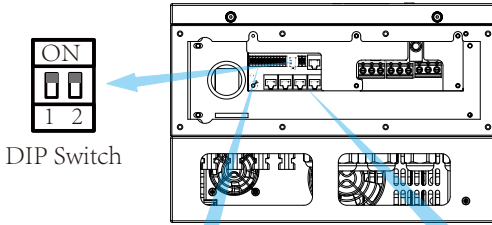

BT: battery temperature sensor for lead acid battery.

HM: current transformer for "zero export to CT" mode.

GV/GS: dry contact signal for startup the diesel generator.

When the "GEN signal" is active, the open contact (GV/GS) will switch on (no voltage output). If the "Signal ISLAND MODE" is ticked, the GS port will be the dry contact signal for startup the diesel generator. If "Signal ISLAND MODE" is not ticked, the GV port will be the dry contact signal for startup the diesel generator. ATS: 230V output port when inverter is on.

RSD_12V: When battery is connected and the inverter is in "ON" status, it will provide 12Vdc.

DIP switch: Parallel communication resistor
If the number of inverters in the parallel system is less than or equal to 6, all inverter's DIP switch (1&2) need be ON position.

If the number of inverters in parallel system exceeds 6, the main 6pcs inverter's DIP switch needs to be ON position. And the other inverter DIP switch (1&2) needs to be OFF position.

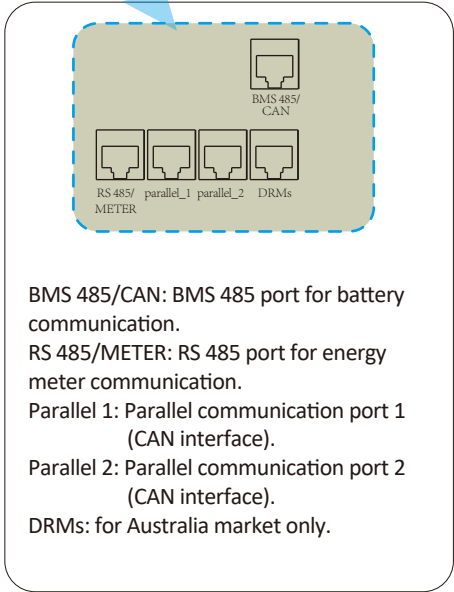

BMS 485/CAN: BMS 485 port for battery communication.

RS 485/METER: RS 485 port for energy meter communication.

Parallel 1: Parallel communication port 1 (CAN interface).

Parallel 2: Parallel communication port 2 (CAN interface).

DRMs: for Australia market only.

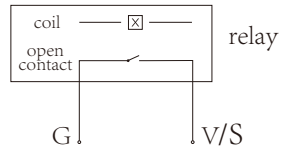

GV/GS
(diesel generator startup signal)

3.3.3 Temperature sensor connection for lead-acid battery

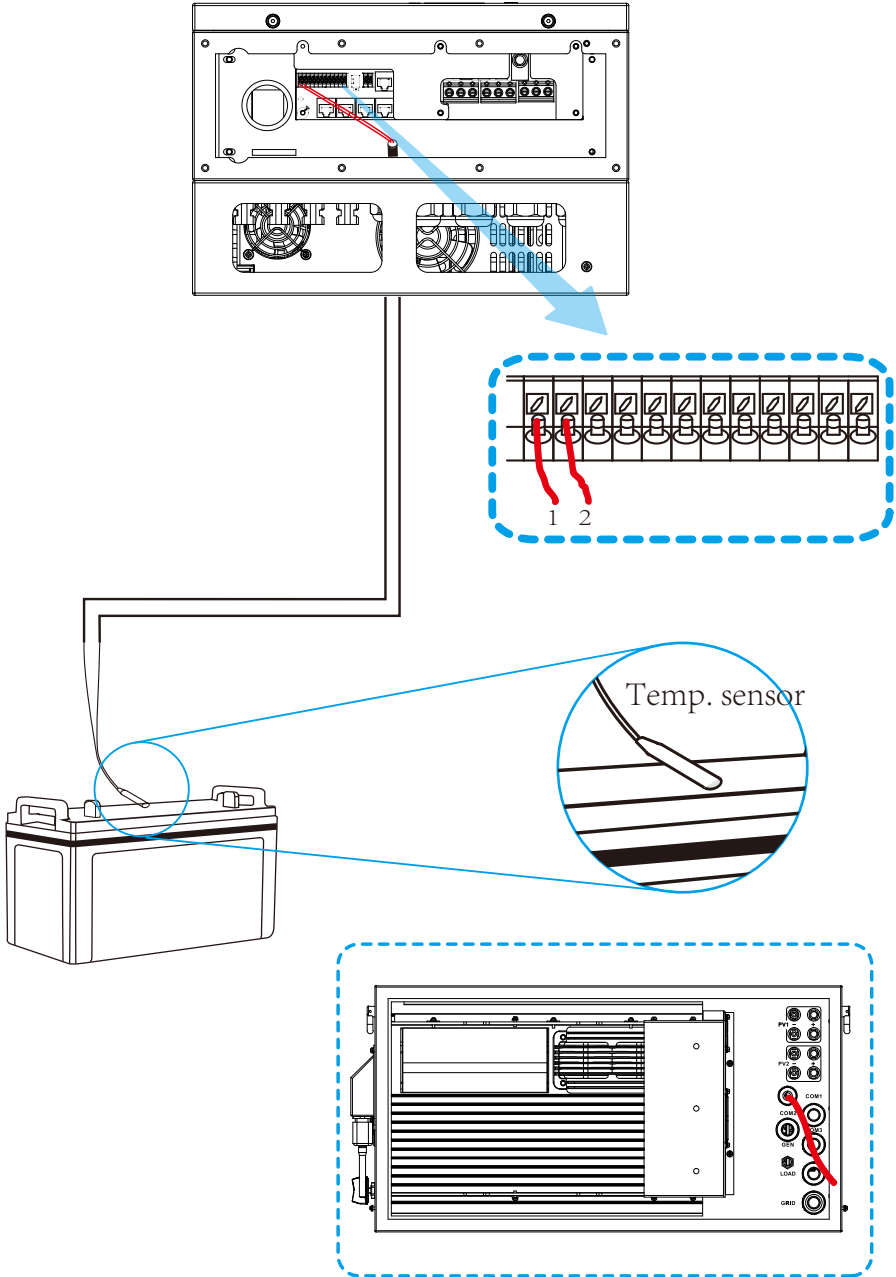

3.4 Grid connection and backup load connection

- Before connecting to the grid, a separate AC breaker must be installed between the inverter and the grid, and also between the backup load and the inverter. This will ensure the inverter can be securely disconnected during maintenance and fully protected from over current. For the 3.6/5/6/7.6/8kW model, the recommended AC breaker for backup load 3.6/5/6kW is 40A, 7.6/8kW is 50A. For the 3.6/5/6/7.6/8kW model, the recommended AC breaker for grid 3.6/5/6kW is 40A, 7.6/8kW is 50A.
- There are three terminal blocks with "Grid" "Load" and "GEN" markings. Please do not misconnect input and output connectors.



All wiring must be performed by a qualified personnel. It is very important for system safety and efficient operation to use appropriate cable for AC input connection. To reduce risk of injury, please use the proper recommended cable as below.

<i>Model</i>	<i>Wire Size</i>	<i>Cable(mm²)</i>	<i>Torque value(max)</i>	<i>Phase</i>
AI-W5.1-3.6P1-EU	12AWG	4	1.2Nm	L+N
AI-W5.1-5/6P1-EU	10AWG	6	1.2Nm	L+N
AI-W5.1-7.6/8P1-EU	8AWG	8	1.2Nm	L+N

Chart 3-3 Recommended Size for AC wires

Please follow below steps to implement AC input/output connection:

1. Before making Grid, load and Gen port connection, be sure to turn off AC breaker or disconnecter first.
2. Remove insulation sleeve 10mm length, unscrew the bolts, insert the wires according to polarities indicated on the terminal block and tighten the terminal screws. Make sure the connection is complete.

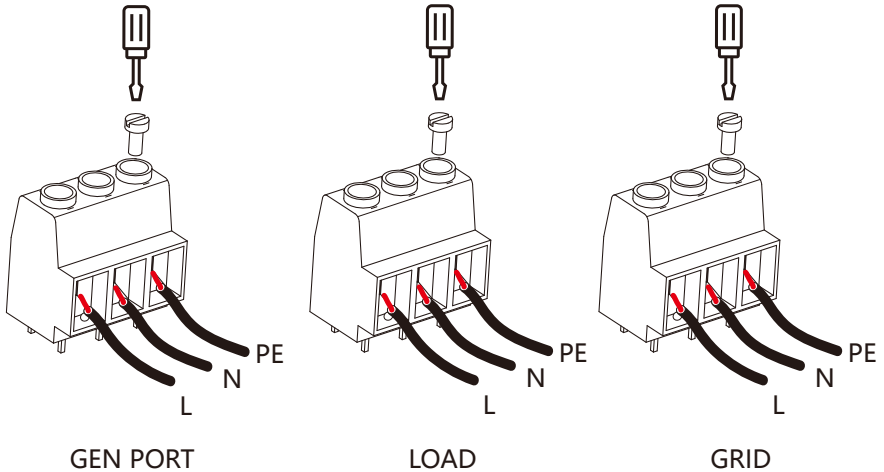
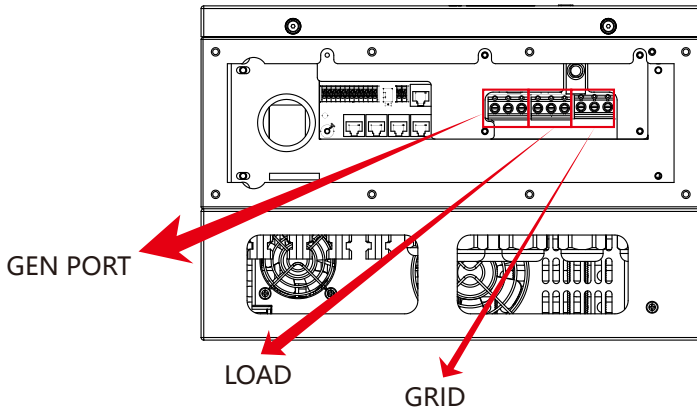

Be sure that AC power source is disconnected before attempting to wire it to the unit.

3. Then, insert AC output wires according to polarities indicated on the terminal block and tighten terminal. Be sure to connect corresponding N wires and PE wires to related terminals as well.
4. Make sure the wires are securely connected.
5. Appliances such as air conditioner are required at least 2-3 minutes to restart because it is required to have enough time to balance refrigerant gas inside of circuit. If a power shortage occurs and recovers in short time, it will cause damage to your connected appliances. To prevent this kind of damage, please check manufacturer of air conditioner if it is equipped with time-delay function before installation. Otherwise, this inverter will trigger overload fault and cut off output to protect your appliance but sometimes it still causes internal damage to the air conditioner

3.5 PV Connection

Before connecting to PV modules, please install a separately DC circuit breaker between inverter and PV modules. It is very important for system safety and efficient operation to use appropriate cable for PV module connection. To reduce risk of injury, please use the proper recommended cable size as below.

<i>Model</i>	<i>Wire Size</i>	<i>Cable(mm²)</i>
AI-W5.1-3.6/5/6/7.6/8P1-EU	12AWG	4

Chart 3-4 Cable size



To avoid any malfunction, do not connect any PV modules with possible current leakage to the inverter. For example, grounded PV modules will cause current leakage to the inverter. When using PV modules, please ensure the PV+ & PV- of solar panel is not connected to the system ground bar.



It is requested to use PV junction box with surge protection. Otherwise, it will cause damage on inverter when lightning occurs on PV modules.

3.5.1 PV Module Selection:

When selecting proper PV modules, please be sure to consider below parameters:

- 1) Open circuit Voltage (Voc) of PV modules not exceeds max. PV array open circuit voltage of inverter.
- 2) Open circuit Voltage (Voc) of PV modules should be higher than min. start voltage.
- 3)The PV modules used to connected to this inverter shall be Class A rating certified according to IEC 61730.

<i>Inverter Model</i>	<i>AI-W5.1-3.6P1-EU</i>	<i>AI-W5.1-5P1-EU</i>	<i>AI-W5.1-6P1-EU</i>	<i>AI-W5.1-7.6P1-EU</i>	<i>AI-W5.1-8P1-EU</i>
PV Input Voltage	370V (125V~500V)				
PV Array MPPT Voltage Range	150V-425V				
No. of MPP Trackers	2				
No. of Strings per MPP Tracker	1+1	1+1	1+1	2+2	2+2

Chart 3-5

3.6 CT Connection

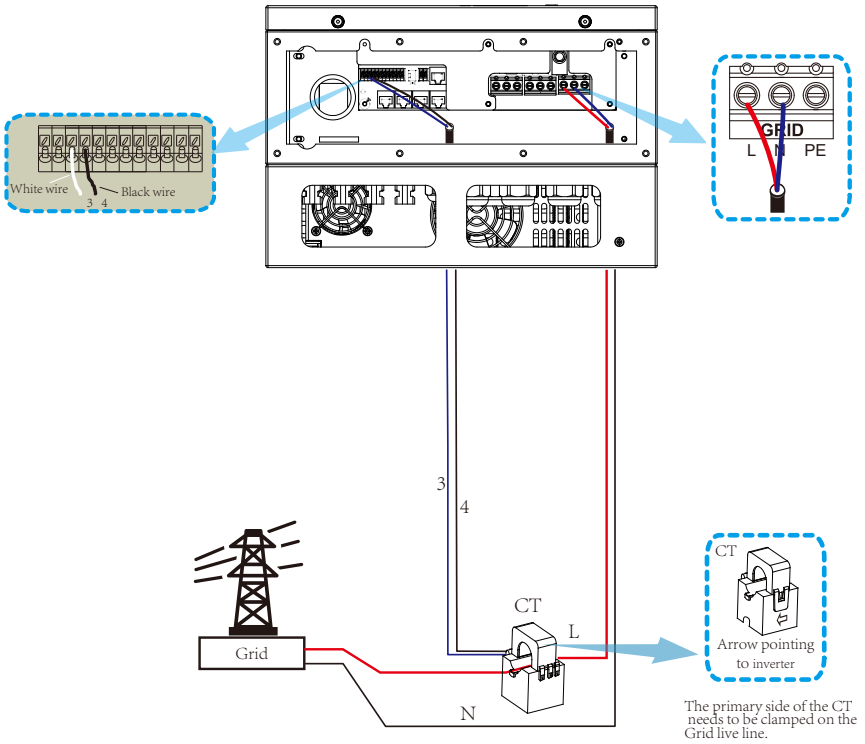

***Note:** when the reading of the load power on the LCD is not correct, please reverse the CT arrow.

3.6.1 Meter Connection

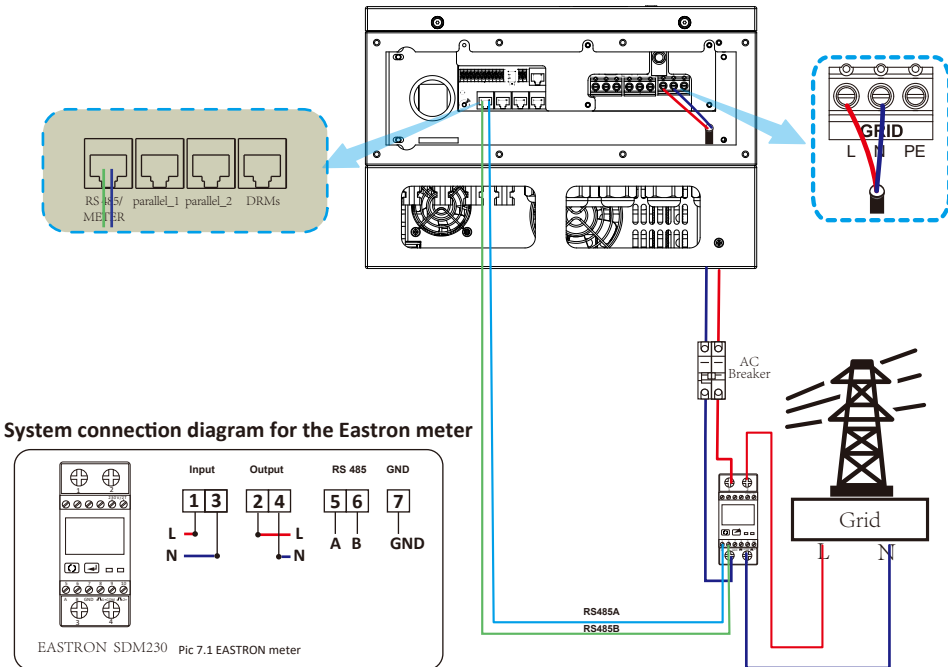
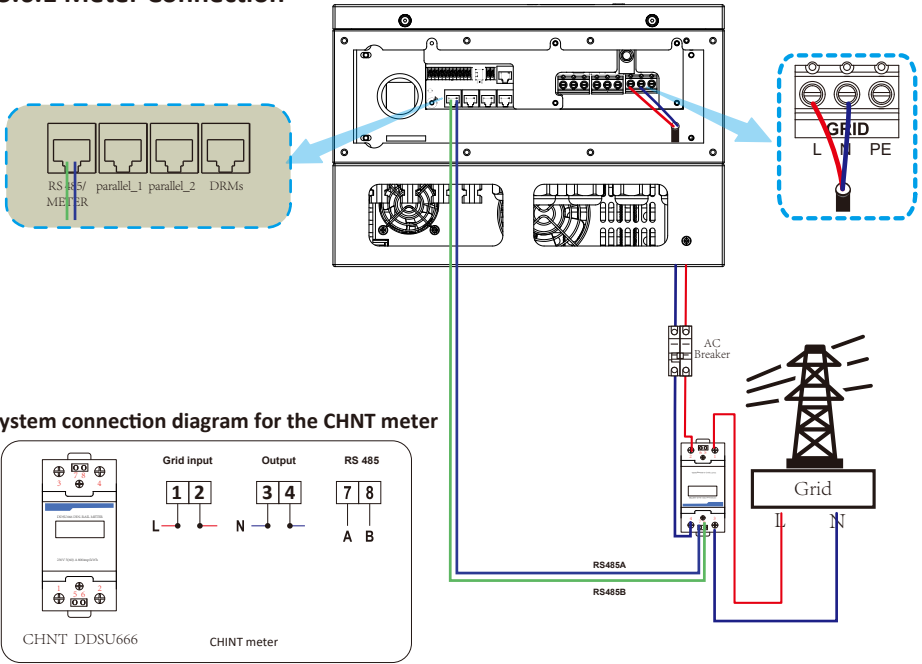



Note:

In final installation, breaker certified according to IEC 60947-1 and IEC 60947-2 shall be installed with the equipment.

3.7 Earth Connection(mandatory)

Ground cable shall be connected to ground plate on grid side this prevents electric shock if the original protective conductor fails.

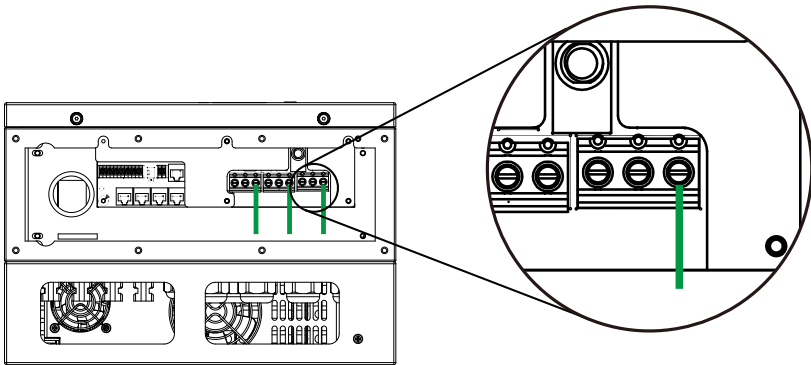

Earth connection(Copper wires)

<i>Model</i>	<i>Wire Size</i>	<i>Cable(mm²)</i>	<i>Torque value(max)</i>
AI-W5.1-3.6P1-EU	12AWG	4	1.2Nm
AI-W5.1-5/6P1-EU	10AWG	6	1.2Nm
AI-W5.1-7.6/8P1-EU	8AWG	8	1.2Nm

The conductor should be made of the same metal as the phase conductors.

3.8 WIFI Connection

For the configuration of Wi-Fi Plug, please refer to illustrations of the Wi-Fi Plug. The Wi-Fi Plug is not a standard configuration, it's optional.

3.9 Wiring System for Inverter

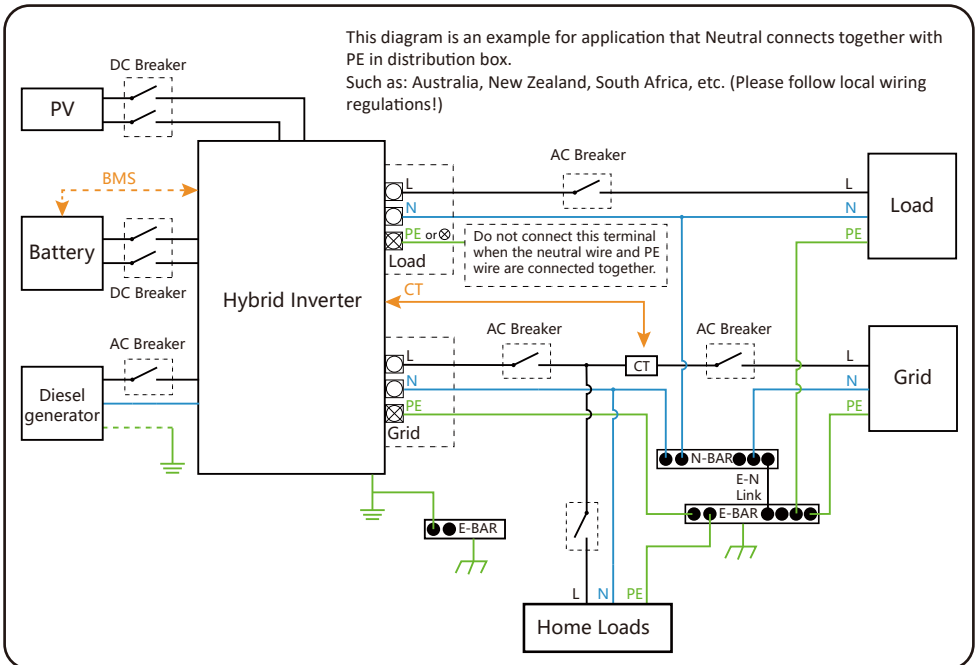
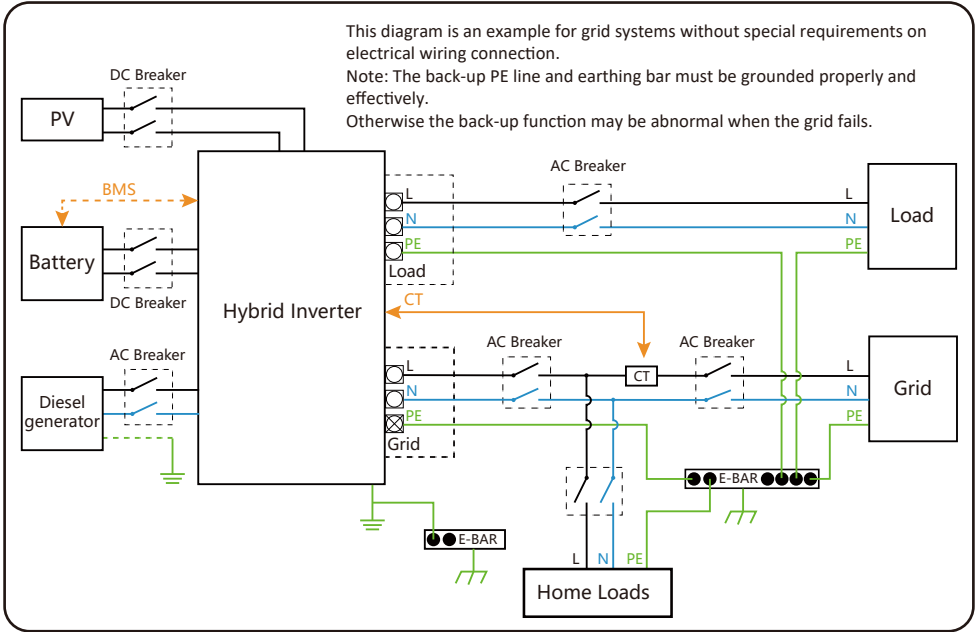

3.10 Typical application diagram of diesel generator

— CAN
 — L wire
 — N wire
 — PE wire

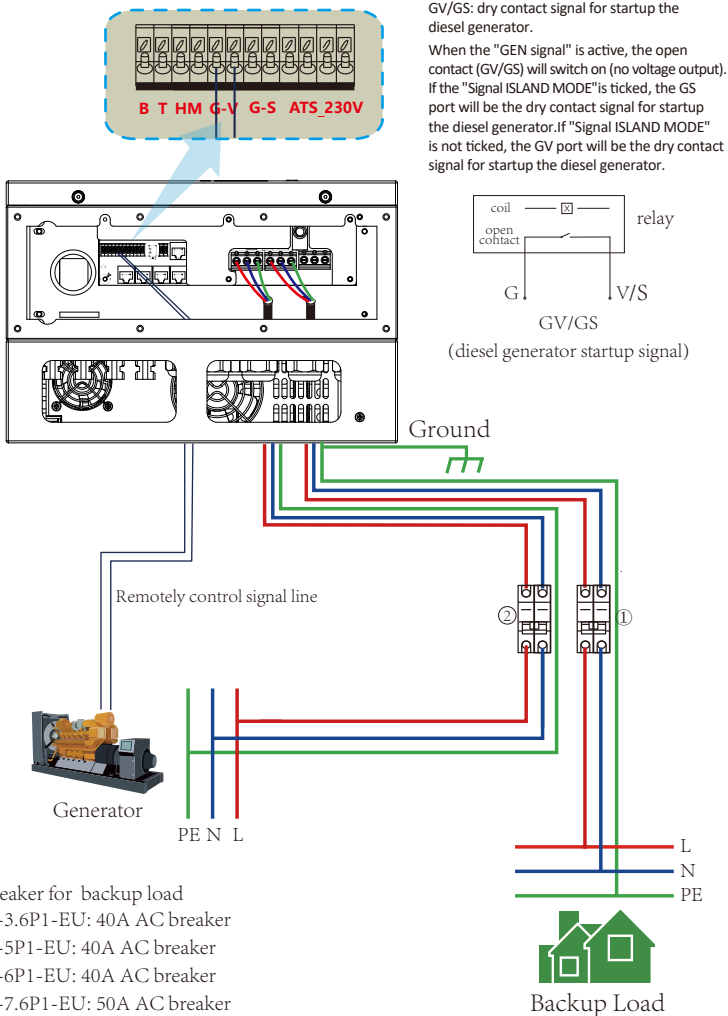

GV/GS: dry contact signal for startup the diesel generator.

When the "GEN signal" is active, the open contact (GV/GS) will switch on (no voltage output). If the "Signal ISLAND MODE" is ticked, the GS port will be the dry contact signal for startup the diesel generator. If "Signal ISLAND MODE" is not ticked, the GV port will be the dry contact signal for startup the diesel generator.

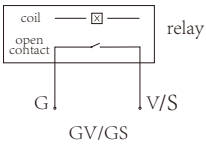

- ① AC Breaker for backup load
 - AI-W5.1-3.6P1-EU: 40A AC breaker
 - AI-W5.1-5P1-EU: 40A AC breaker
 - AI-W5.1-6P1-EU: 40A AC breaker
 - AI-W5.1-7.6P1-EU: 50A AC breaker
 - AI-W5.1-8P1-EU: 50A AC breaker

- ② AC Breaker for Generator port
 - AI-W5.1-3.6P1-EU: 40A AC breaker
 - AI-W5.1-5P1-EU: 40A AC breaker
 - AI-W5.1-6P1-EU: 40A AC breaker
 - AI-W5.1-7.6P1-EU: 50A AC breaker
 - AI-W5.1-8P1-EU: 50A AC breaker

3.11 Single phase parallel connection diagram

— CAN — L wire — N wire — PE wire

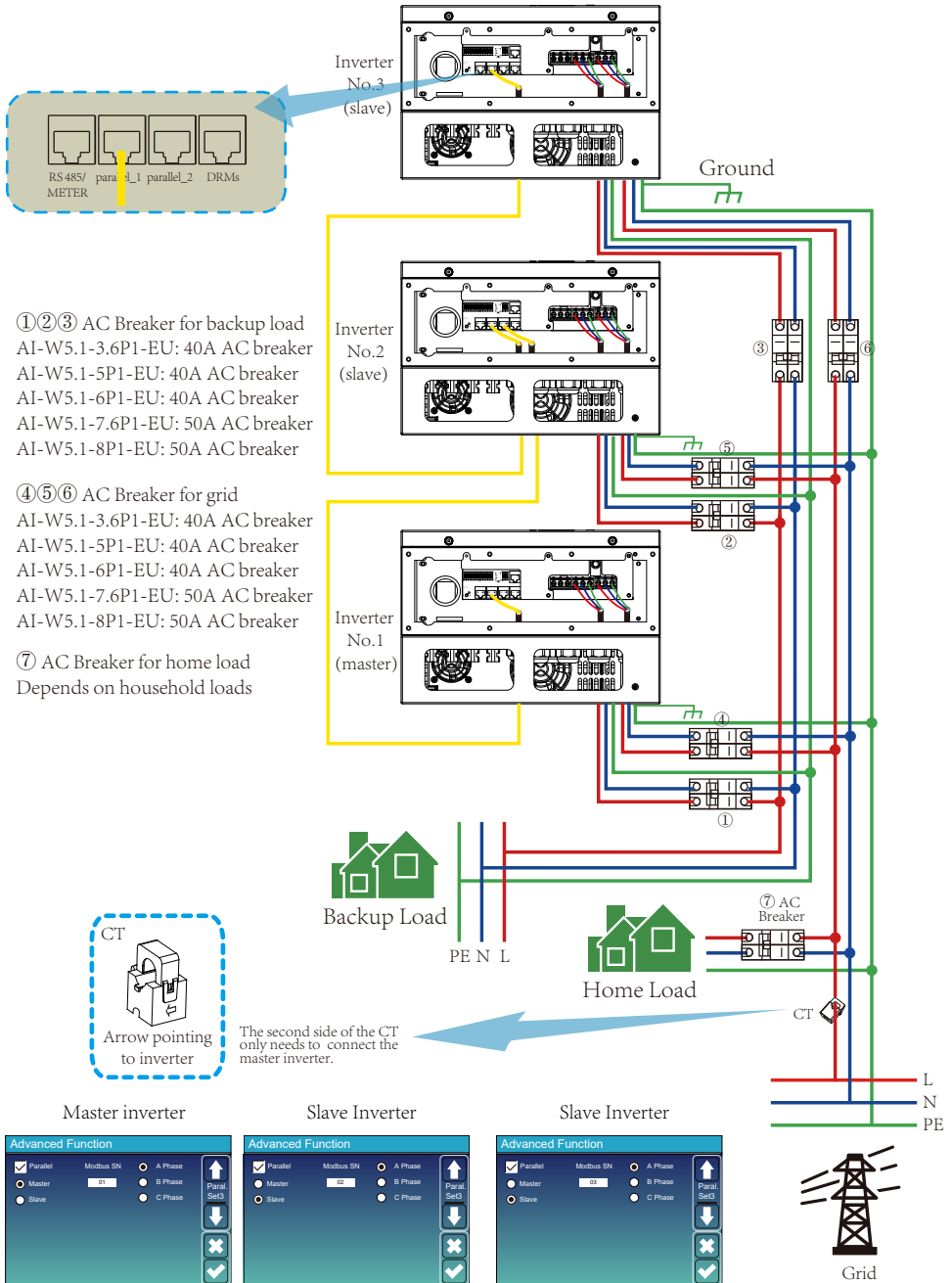

3.12 Three phase Parallel Inverter

- ① AC Breaker for backup load
AI-W5.1-3-6P1-EU; 40A AC breaker
AI-W5.1-5P1-EU; 40A AC breaker
AI-W5.1-6P1-EU; 40A AC breaker
AI-W5.1-7-6P1-EU; 50A AC breaker
AI-W5.1-8P1-EU; 50A AC breaker

- ② AC Breaker for grid
AI-W5.1-3-6P1-EU; 40A AC breaker
AI-W5.1-5P1-EU; 40A AC breaker
AI-W5.1-6P1-EU; 40A AC breaker
AI-W5.1-7-6P1-EU; 50A AC breaker
AI-W5.1-8P1-EU; 50A AC breaker

- ③ AC Breaker for home load
Depends on household loads

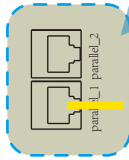

— CAN — L wire — N wire — PE wire

A Phase Inverter No.1 (master) B Phase Inverter No.2 (master) C Phase Inverter No.3 (master)

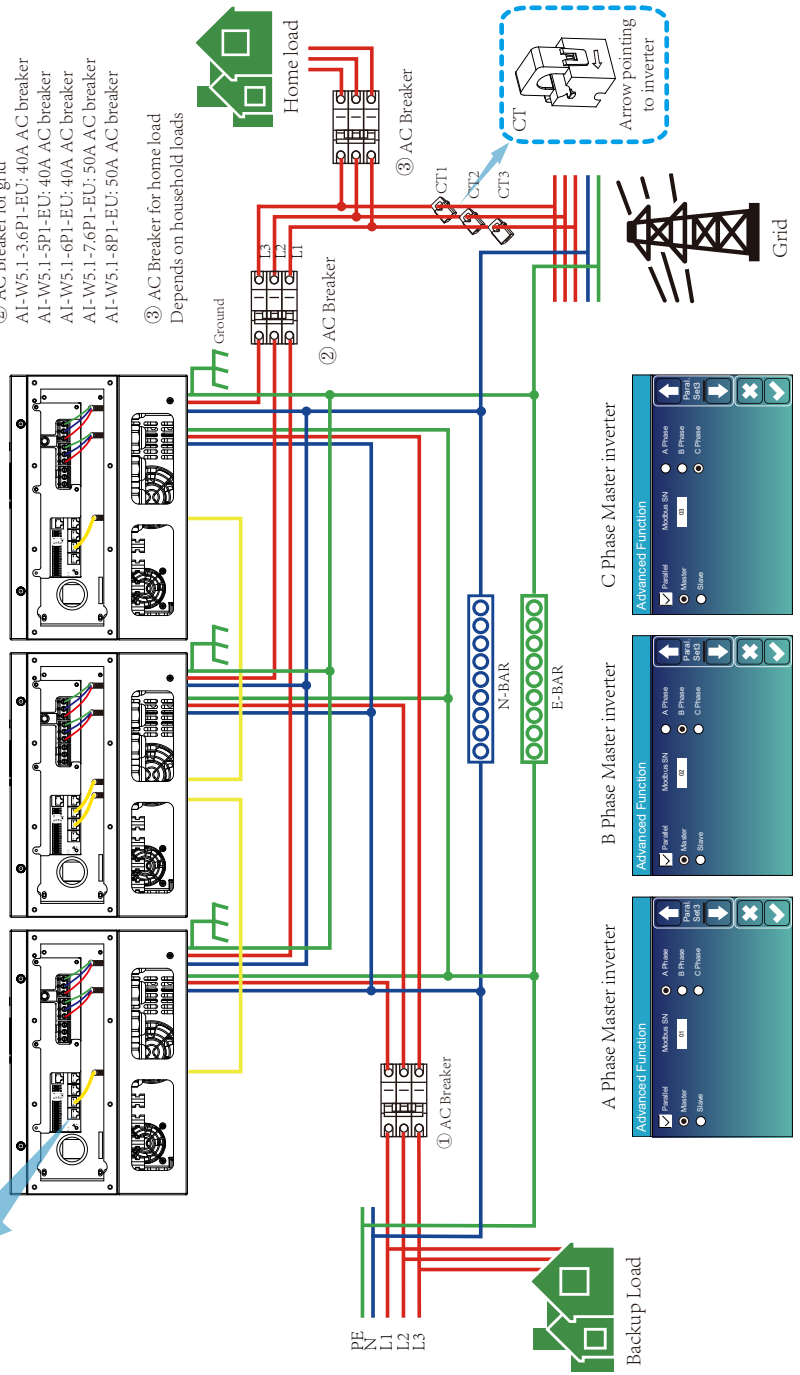

4. OPERATION

4.1 Power ON/OFF

Once the unit has been properly installed and the batteries are connected well, simply press On/Off button(located on the left side of the case) to turn on the unit. When system without battery connected, but connect with either PV or grid, and ON/OFF button is switched off, LCD will still light up(Display will show OFF), In this condition, when switch on ON/OFF button and select NO battery, system can still work.

4.2 Operation and Display Panel

The operation and display panel, shown in below chart, is on the front panel of the inverter. It includes four indicators, four function keys and a LCD display, indicating the operating status and input/output power information.

<i>LED Indicator</i>		<i>Messages</i>
DC	Green led solid light	PV Connection normal
AC	Green led solid light	Grid Connection normal
Normal	Green led solid light	Inverter operating normal
Alarm	Red led solid light	Malfunction or warning

Chart 4-1 LED indicators

<i>Function Key</i>	<i>Description</i>
Esc	To exit setting mode
Up	To go to previous selection
Down	To go to next selection
Enter	To confirm the selection

Chart 4-2 Function Buttons

5. LCD Display Icons

5.1 Main Screen

The LCD is touchscreen, below screen shows the overall information of the inverter.

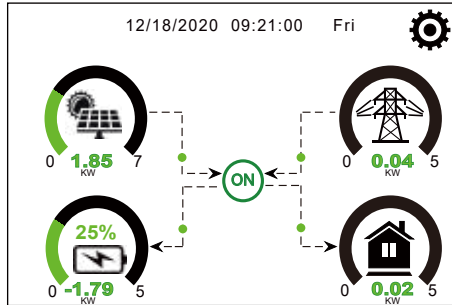

1.The icon in the center of the home screen indicates that the system is Normal operation. If it turns into "comm./FXX" , it means the inverter has communication errors or other errors, the error message will display under this icon(FXX errors, detail error info can be viewed in the System Alarms menu).

2.At the top of the screen is the time.

3.System Setup Icon, Press this set button,you can enter into the system setup screen which including Basic Setup, Battery Setup, Grid Setup, System Work Mode, Generator port use, Advanced function and Li-Batt info.

4.The main screen showing the info including Solar, Grid, Load and Battery. Its also displaying the energy flow direction by arrow. When the power is approximate to high level, the color on the panels will changing from green to red so system info showing vividly on the main screen.

- PV power and Load power always keep positive.
- Grid power negative means sell to grid, positive means get from grid.
- Battery power negative means charge, positive means discharge.

5.1.1 LCD operation flow chart

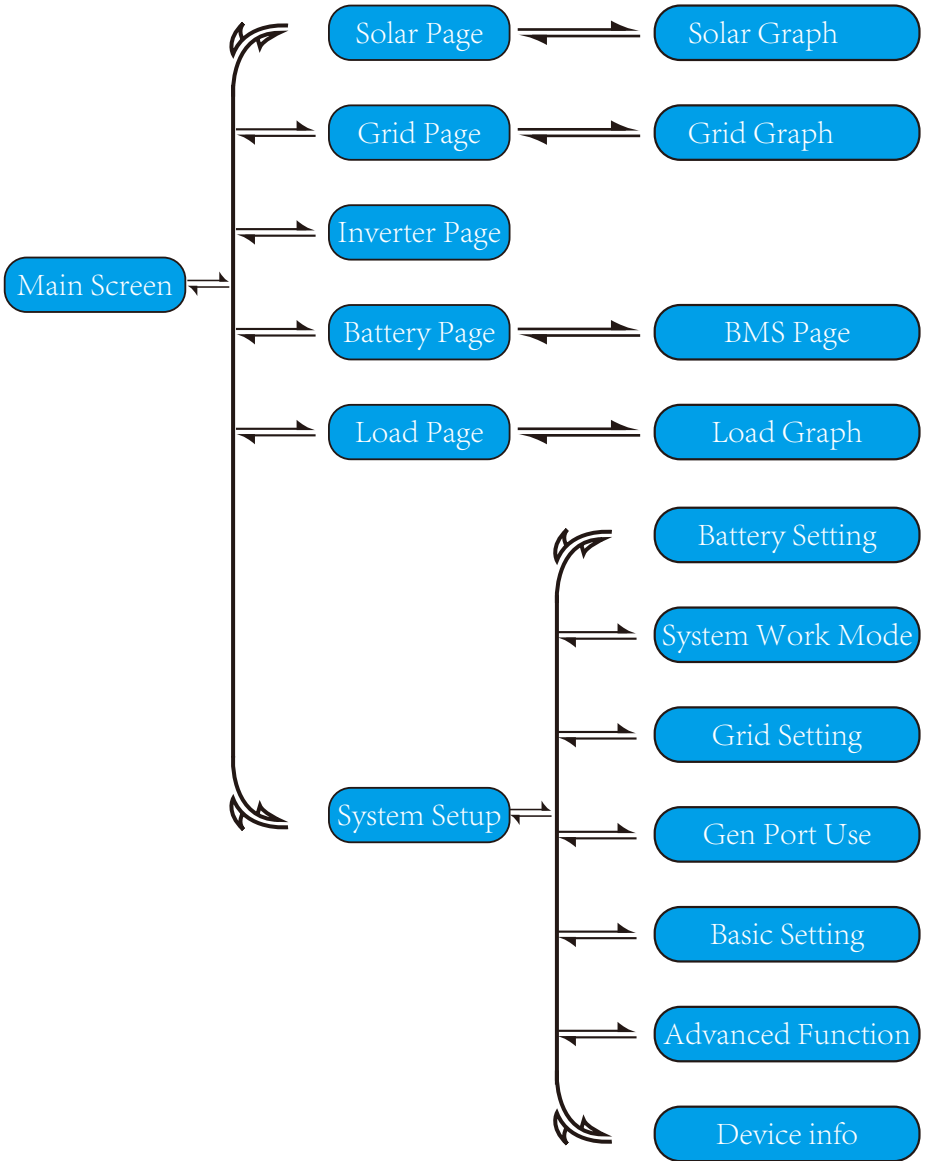

5.2 Solar Power Curve

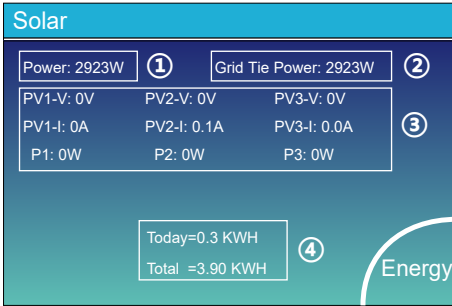

This is Solar Panel detail page.

- (1) Solar Panel Generation.
- (2) **Grid Tie Power:** when there's a string inverter AC couple at the grid or load side of hybrid inverter and there's a meter installed for the string inverter, then the hybrid inverter LCD will show the string inverter output power on its PV icon. Please make sure the meter can communicate with the hybrid inverter successfully.
- (3) Voltage, Current, Power for each MPPT.
- (4) Solar Panel energy for Day and Total. Press the "Energy" button will enter into the power curve page.

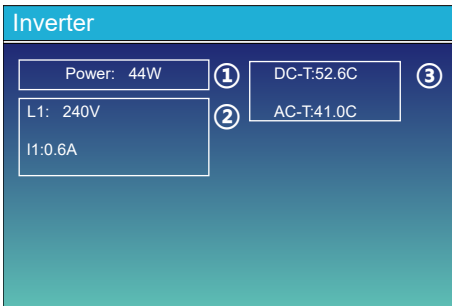

This is Inverter detail page.

- (1) Inverter Generation.
- (2) Voltage, Current, Power for each Phase.
- (3) *DC-T: mean DC-DC temperature, AC-T: mean Heat-sink temperature.
*Note: this part info is not available for some LCD FW.

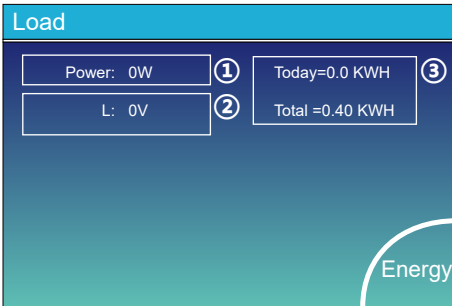

This is Back-up Load detail page.

- (1) Back-up Power.
- (2) Voltage, Power for each Phase.
- (3) Back-up consumption for Day and Total.

Press the "Energy" button will enter into the power curve page.

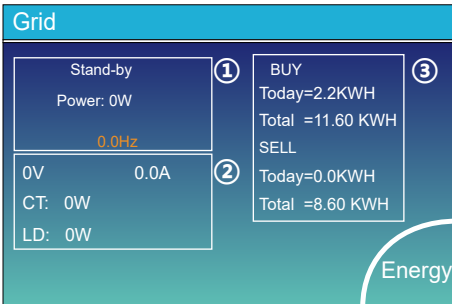

This is Grid detail page.

- (1) Status, Power, Frequency.
 - (2) L: Voltage for each Phase
CT: Power detected by the external current sensors
LD: Power detected using internal sensors on AC grid in/out breaker
 - (3) BUY: Energy from Grid to Inverter, SELL: Energy from Inverter to grid.
- Press the "Energy" button will enter into the power curve page.

Batt

Stand-by

SOC: 36%

U:50.50V

I:-58.02A

Power: -2930W

Temp:30.0C

Li-BMS

Li-BMS

Mean Voltage:50.34V Charging Voltage :53.2V

Total Current:55.00A Discharging Voltage :47.0V

Mean Temp :23.5C Charging current :50A

Total SOC :38% Discharging current :25A

Dump Energy:57Ah

Sum Data

Details Data

Li-BMS

	Volt	Curr	Temp	SOC	Energy	Charge Volt	Charge Curr	Fault
1	50.38V	19.70A	30.9C	52.0%	26.0Ah	0.0V	0.0A	0100
2	50.33V	19.10A	31.0C	51.0%	25.5Ah	53.2V	25.0A	0100
3	50.30V	18.90A	30.2C	12.0%	6.0Ah	53.2V	25.0A	0100
4	0.00V	0.00A	0.0C	0.0%	0.0Ah	0.0V	0.0A	0100
5	0.00V	0.00A	0.0C	0.0%	0.0Ah	0.0V	0.0A	0100
6	0.00V	0.00A	0.0C	0.0%	0.0Ah	0.0V	0.0A	0100
7	0.00V	0.00A	0.0C	0.0%	0.0Ah	0.0V	0.0A	0100
8	0.00V	0.00A	0.0C	0.0%	0.0Ah	0.0V	0.0A	0100
9	0.00V	0.00A	0.0C	0.0%	0.0Ah	0.0V	0.0A	0100
10	0.00V	0.00A	0.0C	0.0%	0.0Ah	0.0V	0.0A	0100
11	0.00V	0.00A	0.0C	0.0%	0.0Ah	0.0V	0.0A	0100
12	0.00V	0.00A	0.0C	0.0%	0.0Ah	0.0V	0.0A	0100
13	0.00V	0.00A	0.0C	0.0%	0.0Ah	0.0V	0.0A	0100
14	0.00V	0.00A	0.0C	0.0%	0.0Ah	0.0V	0.0A	0100
15	0.00V	0.00A	0.0C	0.0%	0.0Ah	0.0V	0.0A	0100

Sum Data

Details Data

This is Battery detail page.

if you use Lithium Battery, you can enter BMS page.

5.3 Curve Page-Solar & Load & Grid

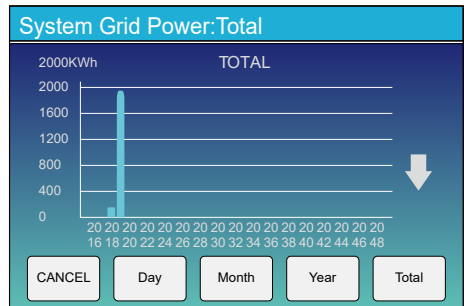
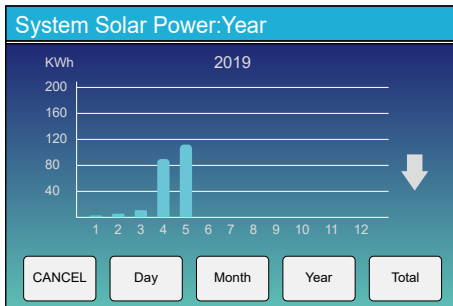
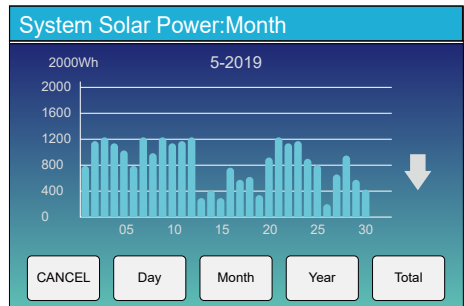
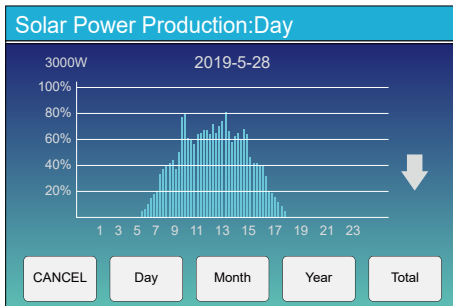

Solar power curve for daily, monthly, yearly and total can be roughly checked on the LCD, for more accuracy power generation, pls check on the monitoring system. Click the up and down arrow to check power curve of different period.

5.4 System Setup Menu

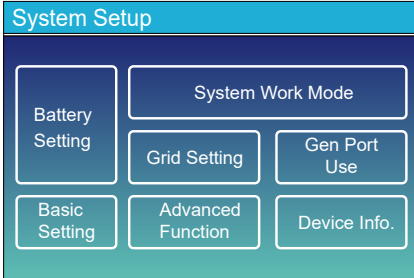

This is System Setup page.

5.5 Basic Setup Menu

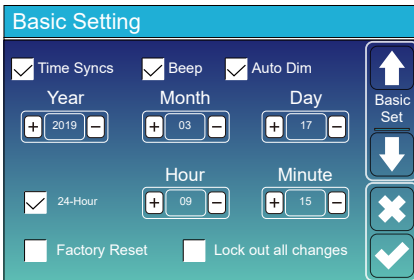

Factory Reset: Reset all parameters of the inverter.
Lock out all changes: Enable this menu for setting parameters that require locking and cannot be set up. Before performing a successful factory reset and locking the systems, to keep all changes you need to type in a password to enable the setting. The password for factory settings is 9999 and for lock out is 7777.

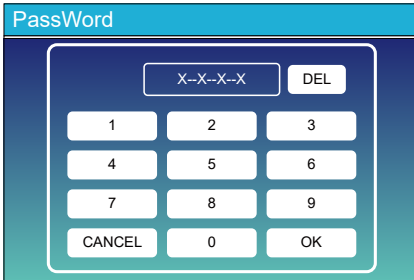

Factory Reset Password: 9999

Lock out all changes Password: 7777

System selfchek: After ticking this item, it needs input the password. The default password is 1234

5.6 Battery Setup Menu

Battery Setting

Batt Mode

Lithium Batt Capacity 400Ah

Use Batt V Max A Charge 40A

Use Batt % Max A Discharge 40A

No Batt

Activate Battery Disable Float Charge

Low Power Mode<Low Batt

Batt Mode

↑

↓

✕

✓

Battery capacity: it tells Deye hybrid inverter to know your battery bank size.

Use Batt V: Use Battery Voltage for all the settings (V).

Use Batt %: Use Battery SOC for all the settings (%).

Max. A charge/discharge: Max battery charge/discharge current(0-90A for 3.6kW model, 0-120A for 5kW model, 0-135A for 6kW model, 0-190A for 7.6/8kW model).

For AGM and Flooded, we recommend Ah battery size x 20%= Charge/Discharge amps.

. For Lithium, we recommend Ah battery size x 50% = Charge/Discharge amps.

. For Gel, follow manufacturer' s instructions.

No Batt: tick this item if no battery is connected to the system.

Active battery: This feature will help recover a battery that is over discharged by slowly charging from the solar array or grid.

Disable Float Charge: For the lithium battery with BMS communication, the inverter will keep the charging voltage at the current voltage when the BMS charging current requested is 0. It is used to help prevent battery from being overcharged.

Low Power Mode<Low Batt: if selected and when battery SOC is less then "Low Bat" value, the self-consumption power of inverter will be from grid and battery simultaneously. If unselected, the self-consumption power of inverter will be mainly from grid.

Battery Setting

Start 30%

A 40A

Gen Charge Grid Charge

Gen Signal Grid Signal

Gen Force Low Noise Mode

Batt Set2

↑

↓

✕

✓

This is Battery Setup page. ① ③

Start =30%: Percent S.O.C at 30% system will AutoStart a connected generator to charge the battery bank.

A = 40A: Charge rate of 40A from the attached generator in Amps.

Gen Charge: uses the gen input of the system to charge battery bank from an attached generator.

Gen Signal: Normally open relay that closes when the Gen Start signal state is active.

Gen Force: When the generator is connected, it is forced to start the generator without meeting other conditions.

Low Noise Mode: In this mode, inverter will work in "low noise mode".

This is Grid Charge, you need select. ②

Start =30%: No use, Just for customization.

A = 40A: It indicates the Current that the Grid charges the Battery.

Grid Charge: It indicates that the grid charges the battery.

Grid Signal: Disable.

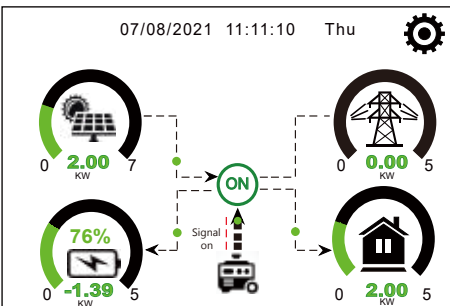

This page tells the PV and diesel generator power the load and battery.

Generator

Power: 1392W Today=0.0 KWH
 Total =2.20 KWH

L1: 228V

Freq:50.0Hz

This page tells generator output voltage, frequency, power. And, how much energy is used from generator.

Battery Setting

Lithium Mode

Shutdown

Low Batt

Restart

Batt Set3

Lithium Mode: This is BMS protocol. Please reference the document (Approved Battery).

Shutdown 10%: It indicates the inverter will shutdown if the SOC below this value.

Low Batt 20%: It indicates the inverter will alarm if the SOC below this value.

Restart 40%: Battery voltage at 40% AC output will resume.

Battery Setting

Float V ①	<input type="text" value="53.6V"/>	Shutdown ③	<input type="text" value="20%"/>
Absorption V	<input type="text" value="57.6V"/>	Low Batt	<input type="text" value="35%"/>
Equalization V	<input type="text" value="57.6V"/>	Restart	<input type="text" value="50%"/>
Equalization Days	<input type="text" value="30 days"/>	TEMPCO(mV/C/Cell)	② <input type="text" value="-5"/>
Equalization Hours	<input type="text" value="3.0 hours"/>	Batt Resistance	<input type="text" value="25mOhms"/>

Batt Set3

There are 3 stages of charging the Battery . **①**

This is for professional installers, you can keep it if you do not know. **②**

Shutdown 20%: The inverter will shutdown if the SOC below this value.

Low Batt 35%: The inverter will alarm if the SOC below this value. **③**

Restart 50%: Battery SOC at 50% AC output will resume.

Recommended battery settings

Battery Type	Absorption Stage	Float Stage	Torque value (every 30 days 3hr)
AGM (or PCC)	14.2V (57.6V)	13.4V (53.6V)	14.2V (57.6V)
Gel	14.1V (56.4V)	13.5V (54.0V)	
Wet	14.7V (59.0V)	13.7V (55.0V)	14.7V (59.0V)
Lithium	Follow its BMS voltage parameters		

5.7 System Work Mode Setup Menu

System Work Mode

Selling First 5000 Max Solar Power ↑
Work Mode 1

Zero Export To Load Solar Sell ↓

Zero Export To CT Solar Sell ✕

Max Sell Power: 5000 Zero-export Power: 20 ✔

Energy pattern: BattFirst LoadFirst

Grid Peak Shaving 5000 Power

Work Mode

Selling First: This Mode allows hybrid inverter to sell back any excess power produced by the solar panels to the grid. If time of use is active, the battery energy also can be sold into grid.

The PV energy will be used to power the load and charge the battery and then excess energy will flow to grid. Power source priority for the load is as follows:

1. Solar Panels.
2. Grid.
3. Batteries (until programable % discharge is reached).

Zero Export To Load: Hybrid inverter will only provide power to the backup load connected. The hybrid inverter will neither provide power to the home load nor sell power to grid. The built-in CT will detect power flowing back to the grid and will reduce the power of the inverter only to supply the local load and charge the battery.

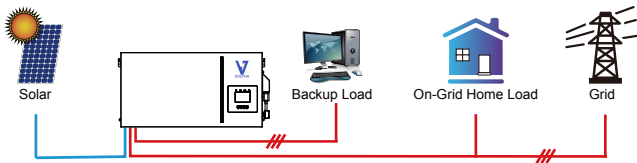

Zero Export To CT: Hybrid inverter will not only provide power to the backup load connected but also give power to the home load connected. If PV power and battery power is insufficient, it will take grid energy as supplement. The hybrid inverter will not sell power to grid. In this mode, a CT is needed. The installation method of the CT please refer to chapter 3.6 CT Connection. The external CT will detect power flowing back to the grid and will reduce the power of the inverter only to supply the local load, charge battery and home load.

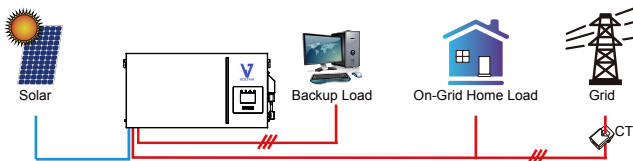

Solar Sell: “Solar sell” is for Zero export to load or Zero export to CT: when this item is active, the surplus energy can be sold back to grid. When it is active, PV Power source priority usage is as follows: load consumption and charge battery and feed into grid.

Max. sell power: Allowed the maximum output power to flow to grid.

Zero-export Power: for zero-export mode, it tells the grid output power. Recommend to set it as 20-100W to ensure the hybrid inverter won't feed power to grid.

Energy Pattern: PV Power source priority.

Batt First: PV power is firstly used to charge the battery and then used to power the load. If PV power is insufficient, grid will make supplement for battery and load simultaneously.

Load First: PV power is firstly used to power the load and then used to charge the battery. If PV power is insufficient, grid will make supplement for battery and load simultaneously.

Max Solar Power: allowed the maximum DC input power.

Grid Peak-shaving: when it is active, grid output power will be limited within the set value. If the load power exceeds the allowed value, it will take PV energy and battery as supplement. If still can't meet the load requirement, grid power will increase to meet the load needs.

System Work Mode

		Time Of Use				
Grid Charge	Gen	Time	Power	Batt		
<input type="checkbox"/>	<input type="checkbox"/>	01:00	5:00	5000	49.0V	
<input type="checkbox"/>	<input type="checkbox"/>	05:00	9:00	5000	50.2V	
<input checked="" type="checkbox"/>	<input type="checkbox"/>	09:00	13:00	5000	50.9V	
<input checked="" type="checkbox"/>	<input type="checkbox"/>	13:00	17:00	5000	51.4V	
<input checked="" type="checkbox"/>	<input type="checkbox"/>	17:00	21:00	5000	47.1V	
<input checked="" type="checkbox"/>	<input type="checkbox"/>	21:00	01:00	5000	49.0V	

Work Mode2

Time of use: it is used to program when to use grid or generator to charge the battery, and when to discharge the battery to power the load. Only tick "Time Of Use" then the follow items (Grid, charge, time, power etc.) will take effect.

Note: when in selling first mode and click time of use, the battery power can be sold into grid.

Grid charge: utilize grid to charge the battery in a time period.

Gen charge: utilize diesel generator to charge the battery in a time period.

Time: real time, range of 01:00-24:00.

Power: Max. discharge power of battery allowed.

Batt(V or SOC %): battery SOC % or voltage at when the action is to happen.

For example:

During 01:00-05:00, when battery SOC is lower than 80%, it will use grid to charge the battery until battery SOC reaches 80%.

During 05:00-08:00 and 08:00-10:00, when battery SOC is higher than 40%, hybrid inverter will discharge the battery until the SOC reaches 40%.

During 10:00-15:00, when battery SOC is higher than 80%, hybrid inverter will discharge the battery until the SOC reaches 80%.

During 15:00-18:00, when battery SOC is higher than 40%, hybrid inverter will discharge the battery until the SOC reaches 40%.

During 18:00-01:00, when battery SOC is higher than 35%, hybrid inverter will discharge the battery until the SOC reaches 35%.

System Work Mode

		Time Of Use				
Grid Charge	Gen	Time	Power	Batt		
<input checked="" type="checkbox"/>	<input type="checkbox"/>	01:00	5:00	5000	80%	
<input type="checkbox"/>	<input type="checkbox"/>	05:00	8:00	5000	40%	
<input type="checkbox"/>	<input type="checkbox"/>	08:00	10:00	5000	40%	
<input type="checkbox"/>	<input type="checkbox"/>	10:00	15:00	5000	80%	
<input type="checkbox"/>	<input type="checkbox"/>	15:00	18:00	5000	40%	
<input type="checkbox"/>	<input type="checkbox"/>	18:00	01:00	5000	35%	

Work Mode2

System Work Mode

Mon	Tue	Wed	Thu	Fri	Sat	Sun
<input checked="" type="checkbox"/>	<input checked="" type="checkbox"/>	<input checked="" type="checkbox"/>	<input checked="" type="checkbox"/>	<input checked="" type="checkbox"/>	<input checked="" type="checkbox"/>	<input type="checkbox"/>

Work Mode4

It allows users to choose which day to execute the setting of “Time of Use”.

For example, the inverter will execute the time of use page on Mon/Tue/Wed/Thu/Fri/Sat only.

5.8 Grid Setup Menu

Grid Setting

Unlock Grid Setting

Grid Mode: 0/16

Grid Frequency: 50HZ 60HZ

INV Output Voltage:

Grid Type: Single Phase
 120/240V Split Phase
 120/208V 3 Phase

Unlock Grid Setting: before changing the grid parameters, please enable this with password of 7777. Then it is allowed to change the grid parameters.

Grid Mode: General Standard、UL1741 & IEEE1547、CPUC RULE21、SRD-UL-1741、CEI 0-21、EN50549_CZ、Australia_A、Australia_B、Australia_C、NewZealand、VDE4105、OVE_Directive_R25、EN50549_CZ_PPDS_L16A、NRS097、G98/G99、G98/G99_NI、ESB Networks(Ireland). Please follow the local grid code and then choose the corresponding grid standard.

Grid Setting/Connect

Normal connect: 60s

Low frequency: High frequency:

Low voltage: High voltage:

Reconnect after trip: 60s

Low frequency: High frequency:

Low voltage: High voltage:

Reconnection Time: PF:

Normal connect: The allowed grid voltage/frequency range when the inverter first time connect to the grid.
Normal Ramp rate: It is the startup power ramp.

Reconnect after trip: The allowed grid voltage /frequency range for the inverter connects the grid after the inverter trip from the grid.

Reconnect Ramp rate: It is the reconnection power ramp.

Reconnection time: The waiting time period for the inverter connects the grid again.

PF: Power factor which is used to adjust inverter reactive power.

Grid Setting/IP Protection

Over voltage U>(10 min. running mean):

HV3	<input type="text" value="265.0V"/>	<input type="text" value="0.10s"/>	HF3	<input type="text" value="51.50Hz"/>	<input type="text" value="0.10s"/>
HV2	<input type="text" value="265.0V"/>	<input type="text" value="0.10s"/>	HF2	<input type="text" value="51.50Hz"/>	<input type="text" value="0.10s"/>
HV1	<input type="text" value="265.0V"/>	<input type="text" value="0.10s"/>	HF1	<input type="text" value="51.50Hz"/>	<input type="text" value="0.10s"/>
LV1	<input type="text" value="185.0V"/>	<input type="text" value="0.10s"/>	LF1	<input type="text" value="48.00Hz"/>	<input type="text" value="0.10s"/>
LV2	<input type="text" value="185.0V"/>	<input type="text" value="0.10s"/>	LF2	<input type="text" value="48.00Hz"/>	<input type="text" value="0.10s"/>
LV3	<input type="text" value="185.0V"/>	<input type="text" value="0.10s"/>	LF3	<input type="text" value="48.00Hz"/>	<input type="text" value="0.10s"/>

HV1: Level 1 overvoltage protection point;
HV2: Level 2 overvoltage protection point; **②** 0.10s—Trip time.
HV3: Level 3 overvoltage protection point.

LV1: Level 1 undervoltage protection point;
LV2: Level 2 undervoltage protection point;
LV3: Level 3 undervoltage protection point.

HF1: Level 1 over frequency protection point;
HF2: Level 2 over frequency protection point;
HF3: Level 3 over frequency protection point.

LF1: Level 1 under frequency protection point;
LF2: Level 2 under frequency protection point;
LF3: Level 3 under frequency protection point.

Grid Setting/F(W)

F(W)

Over frequency: 40%PE/Hz

Start freq f: Stop freq f:

Start delay f: Stop delay f:

Under frequency: 40%PE/Hz

Start freq f: Stop freq f:

Start delay f: Stop delay f:

FW: this series inverter is able to adjust inverter output power according to grid frequency.

Droop f: percentage of nominal power per Hz

For example, "Start freq f > 50.2Hz, Stop freq f < 50.2, Droop f = 40%PE/Hz" when the grid frequency reaches 50.2Hz, the inverter will decrease its active power at Droop f of 40%. And then when grid system frequency is less than 50.2Hz, the inverter will stop decreasing output power.

For the detailed setup values, please follow the local grid code.

Grid Setting/V(W) V(Q)

V(W)

V1	109.0%	P1	100%
V2	110.0%	P2	20%
V3	111.0%	P3	20%
V4	111.0%	P4	20%

V(Q)

Lock-in/Pn	5%	Lock-out/Pn	20%
V1	90.0%	Q1	44%
V2	95.7%	Q2	0%
V3	104.3%	Q3	0%
V4	112.2%	Q4	-60%

Grid Set5

↑

↓

✕

✓

V(W): It is used to adjust the inverter active power according to the set grid voltage.
V(Q): It is used to adjust the inverter reactive power according to the set grid voltage.
 This function is used to adjust inverter output power (active power and reactive power) when grid voltage changes.

Lock-in/Pn 5%: When the inverter active power is less than 5% rated power, the VQ mode will not take effect.
Lock-out/Pn 20%: If the inverter active power is increasing from 5% to 20% rated power, the VQ mode will take effect again.

For example: V2=110%, P2=20%. When the grid voltage reaches the 110% times of rated grid voltage, inverter output power will reduce its active output power to 20% rated power.

For example: V1=90%, Q1=44%. When the grid voltage reaches the 90% times of rated grid voltage, inverter output power will output 44% reactive output power.

For the detailed setup values, please follow the local grid code.

Grid Setting/P(Q) P(F)

P(Q)

P1	0%	Q1	0%
P2	0%	Q2	0%
P3	0%	Q3	0%
P4	0%	Q4	0%

P(PF)

Lock-in/Pn	50%	Lock-out/Pn	50%
P1	0%	PF1	<2.400
P2	0%	PF2	0.000
P3	0%	PF3	0.000
P4	0%	PF4	6.000

Grid Set6

↑

↓

✕

✓

P(Q): It is used to adjust the inverter reactive power according to the set active power.

P(PF): It is used to adjust the inverter PF according to the set active power.
 For the detailed setup values, please follow the local grid code.

Lock-in/Pn 50%: When the inverter output active power is less than 50% rated power, it won't enter the P(PF) mode.

Lock-out/Pn 50%: When the inverter output active power is higher than 50% rated power, it will enter the P(PF) mode.

Note : only when the grid voltage is equal to or higher than 1.05times of rated grid voltage, then the P(PF) mode will take effect.

Grid Setting/LVRT

L/HVR

HV1	115%
LV1	50%

Grid Set7

↑

↓

✕

✓

Reserved: This function is reserved. It is not recommended.

5.9 Generator Port Use Setup Menu

GEN PORT USE

Mode

Generator Input AC couple on grid side

SmartLoad Output AC couple on load side

Micro Inv Input GEN connect to Grid input

On Grid always on

Power: 8000W

AC Couple Fire High: 500W

52.00Hz

ON: 100% OFF: 95%

PORT Set1

↑

↓

✕

✓

Generator input rated power: allowed Max. power from diesel generator.

GEN connect to grid input: connect the diesel generator to the grid input port.

Smart Load Output: This mode utilizes the Gen input connection as an output which only receives power when the battery SOC and PV power is above a user programmable threshold.

e.g. **Power=500W, ON: 100%, OFF=95%:** When the PV power exceeds 500W, and battery bank SOC reaches 100%, Smart Load Port will switch on automatically and power the load connected. When the battery bank SOC < 95% or PV power < 500W, the Smart Load Port will switch off automatically.

Smart Load OFF Batt

• Battery SOC at which the Smart load will switch off.

Smart Load ON Batt

• Battery SOC at which the Smart load will switch on. Also, the PV input power should exceed the setting value (Power) simultaneously and then the Smart load will switch on.

On Grid always on: When click "on Grid always on" the smart load will switch on when the grid is present.

Micro Inv Input: To use the Generator input port as a micro-inverter on grid inverter input (AC coupled), this feature will also work with "Grid-Tied" inverters.

* **Micro Inv Input OFF:** when the battery SOC exceeds setting value, Microinverter or grid-tied inverter will shut down.

* **Micro Inv Input ON:** when the battery SOC is lower than setting value, Microinverter or grid-tied inverter will start to work.

AC Couple Fre High: If choosing "Micro Inv input", as the battery SOC reaches gradually setting value (OFF), During the process, the microinverter output power will decrease linear. When the battery SOC equals to the setting value (OFF), the system frequency will become the setting value (AC couple Fre high) and the Microinverter will stop working. Stop exporting power produced by the microinverter to the grid.

* **Note:** Micro Inv Input OFF and On is valid for some certain FW version only.

* **AC couple on load side:** connecting the output of on-grid inverter at the load port of the hybrid inverter. In this situation, the hybrid inverter will not able to show the load power correctly.

* **AC couple on grid side:** this function is reserved.

* **Note:** Some firmware versions don't have this function.

5.10 Advanced Function Setup Menu

Advanced Function

- Solar Arc Fault ON
- Clear Arc_Fault
- System selfcheck
- DRM
- Signal ISLAND MODE
- BMS_Err_Stop
- Backup Delay: 0ms
- Gen peak-shaving
- CT Ratio: 2000: 1
- CEI 0-21 Report

Navigation: Func Set1, Up, Down, X, Checkmark

Solar Arc Fault ON: This is only for US.

System selfcheck: Disable. this is only for factory.

Gen Peak-shaving: Enable When the power of the generator exceeds the rated value of it, the inverter will provide the redundant part to ensure that the generator will not overload.

DRM: For AS4777 standard

Backup Delay: (0-300)S adjustable

BMS_Err_Stop: When it is active, if the battery BMS failed to communicate with inverter, the inverter will stop working and report fault.

Signal ISLAND MODE: when "signal island mode" is checked and the inverter connects the grid, the ATS port voltage will be 0. When "signal island mode" is checked and the inverter disconnected from the grid, the ATS port voltage will output 230Vac voltage. With this feature and outside NO type relay, it can realize N and PE disconnection or bond.

More details, please refer to left side picture.

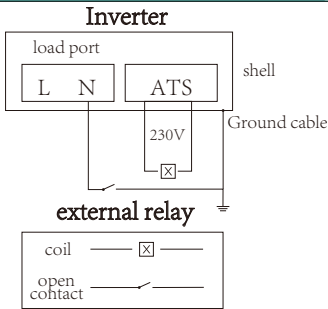

Advanced Function

- DC 1 for WindTurbine
- DC 2 for WindTurbine

V1	90V	0.0A	V7	210V	9.0A
V2	110V	1.5A	V8	230V	10.5A
V3	130V	3.0A	V9	250V	12.0A
V4	150V	4.5A	V10	270V	13.5A
V5	170V	6.0A	V11	290V	15.0A
V6	190V	7.5A	V12	310V	16.5A

Navigation: Wind Set2, Up, Down, X, Checkmark

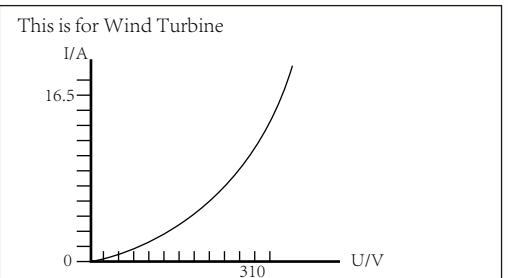

Advanced Function

Parallel Modbus SN A Phase
 Master B Phase
 Slave C Phase

Ex_Meter For CT Meter Select

A Phase CHNT-3P 0/4
 B Phase CHNT-1P
 C Phase Eastron-3P
 Eastron-1P
 Grid Side INV Meter2

Parol. Set3

Ex_Meter For CT: when in Three phase system with CHNT Three phase energy meter (DTSU666), click corresponding phase where hybrid inverter is connected. e.g. when the hybrid inverter output connects to A phase, please click A Phase.

Meter Select: select the corresponding meter type according to the meter installed in the system.

Grid Side INV Meter2: when there's a string inverter AC couple at the grid or load side of hybrid inverter and there's a meter installed for the string inverter, then the hybrid inverter LCD will show the string inverter output power on its PV icon. Please make sure the meter can communicate with the hybrid inverter successfully.

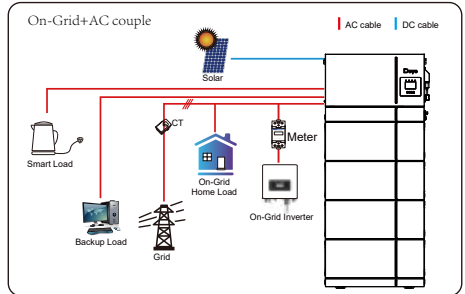
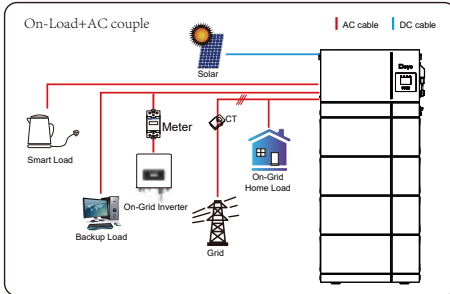

Advanced Function

ATS ON

Func Set4

ATS: It is related with ATS port voltage. it is better in "uncheck" position.

5.11 Device Info Setup Menu

Device Info.

Inverter ID: 1601012001 Flash
 HMI: Ver0302 MAIN:Ver 0-5213-0717

Alarms Code	Occurred
F64 Heatsink_HighTemp_Fault	2019-03-11 15:56
F64 Heatsink_HighTemp_Fault	2019-03-08 10:46
F64 Heatsink_HighTemp_Fault	2019-03-08 10:45

Device Info

This page show Inverter ID, Inverter version and alarm codes.

HMI: LCD version

MAIN: Control board FW version

6. Mode

Mode I: Basic

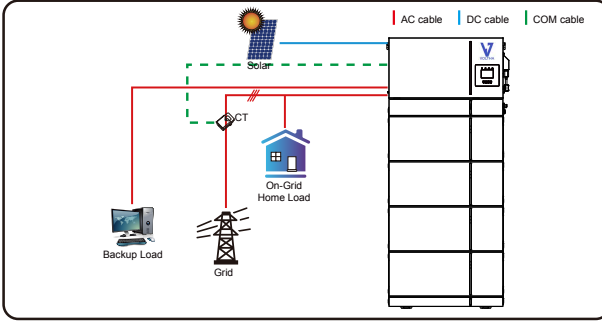

Mode II: With Generator

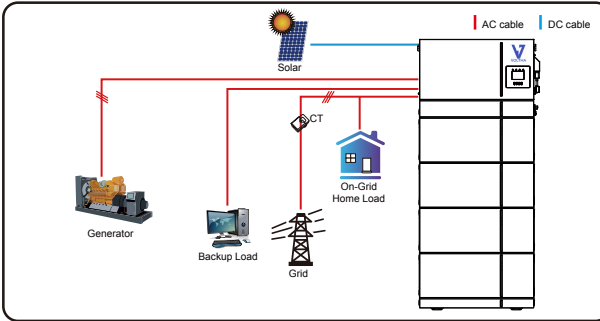

Mode III: With Smart-Load

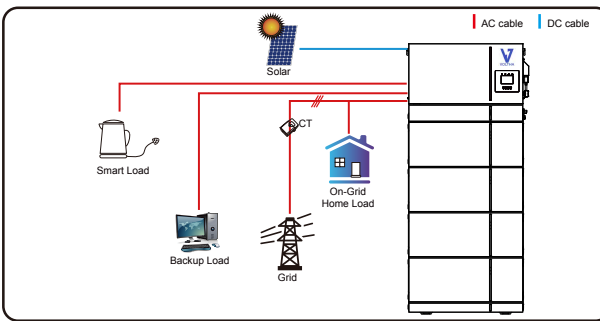

Mode IV: AC Couple

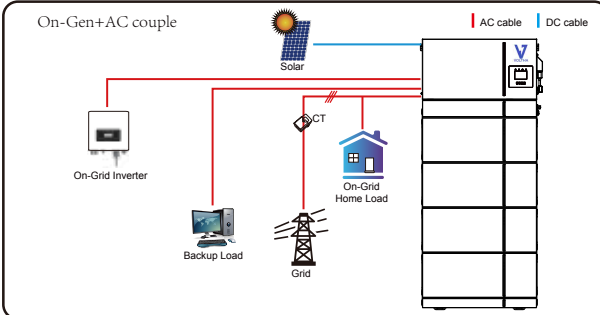

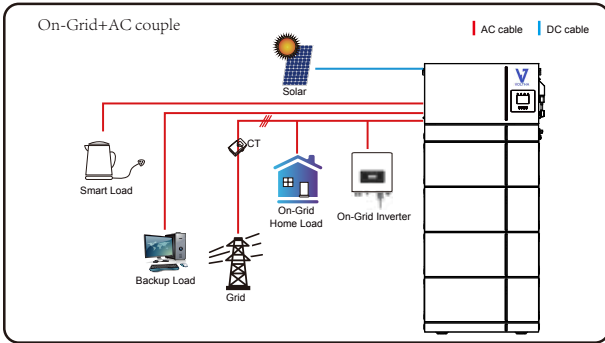
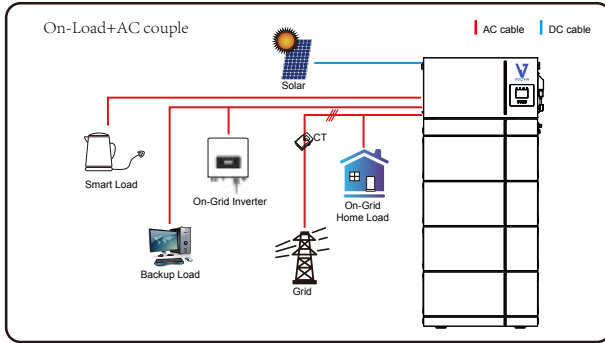

The 1st priority power of the system is always the PV power, then 2nd and 3rd priority power will be the battery bank or grid according to the settings. The last power backup will be the Generator if it is available.

7. Fault information and processing

The energy storage inverter is designed according to the grid-connected operation standard and meets the safety requirements and electromagnetic compatibility requirements. Before leaving the factory, the inverter undergoes several rigorous tests to ensure that the inverter can operate reliably.



If any of the fault messages listed in Table 7-1 appear on your inverter and the fault has not been removed after restarting, please contact your local dealer or service center. You need to have the following information ready.

1. Inverter serial number;
2. Distributor or service center of the inverter ;
3. On-grid power generation date;
4. The problem description (including the fault code and indicator status displayed on the LCD) is as detailed as possible.
5. Your contact information. In order to give you a clearer understanding of the inverter's fault information, we will list all possible fault codes and their descriptions when the inverter is not working properly.

Error code	Description	Solutions
F08	GFDI_Relay_Failure	<ol style="list-style-type: none"> 1. When inverter is in Split phase(120/240Vac) or three-phase system (120/208Vac) system, the backup load port N line needs to connect ground; 2. If the fault still exists, please contact us for help.
F13	Working mode change	<ol style="list-style-type: none"> 1. When the grid type and frequency changed it will report F13; 2. When the battery mode was changed to "No battery" mode, it will report F13; 3. For some old FW version, it will report F13 when the system work mode changed; 4. Generally, it will disappear automatically when shows F13; 5. If still same, and turn off the DC switch and AC switch and wait for one minute and then turn on the DC/AC switch; 6. Seek help from us, if can not go back to normal state.
F18	AC over current fault of hardware	<p>AC side over current fault</p> <ol style="list-style-type: none"> 1. Please check whether the backup load power and common load power are within the range; 2. Restart and check whether it is in normal; 3. Seek help from us, if can not go back to normal state.
F20	DC over current fault of the hardware	<p>DC side over current fault</p> <ol style="list-style-type: none"> 1. Check PV module connect and battery connect; 2. When in the off-grid mode, the inverter startup with big power load, it may report F20. Please reduce the load power connected; 3. Turn off the DC switch and AC switch and then wait one minute,then turn on the DC/AC switch again; 4. Seek help from us, if can not go back to normal state.
F22	Tz_EmergStop_Fault	Please contact your installer for help.
F23	AC leakage current is transient over current	<p>Leakage current fault</p> <ol style="list-style-type: none"> 1. Check PV side cable ground connection. 2. Restart the system 2~3 times. 3. If the fault still exists, please contact us for help.
F24	DC insulation impedance failure	<p>PV isolation resistance is too low</p> <ol style="list-style-type: none"> 1. Check the connection of PV panels and inverter is firmly and correctly; 2. Check whether the PE cable of inverter is connected to ground; 3. Seek help from us, if can not go back to normal state.
F26	The DC busbar is unbalanced	<ol style="list-style-type: none"> 1. Please wait for a while and check whether it is normal; 2. When the hybrid in split phase mode, and the load of L1 and load of L2 is big different, it will report the F26. 3. Restart the system 2~3 times. 4. Seek help from us, if can not go back to normal state.
F29	Parallel CANBus fault	<ol style="list-style-type: none"> 1. When in parallel mode, check the parallel communication cable connection and hybrid inverter communication address setting; 2. During the parallel system startup period, inverters will report F29. when all inverters are in ON status, it will disappear automatically; 3. If the fault still exists, please contact us for help.

Error code	Description	Solutions
F34	AC Overcurrent fault	<ol style="list-style-type: none"> 1. Check the backup load connected, make sure it is in allowed power range; 2. If the fault still exists, please contact us for help.
F35	No AC grid	<p>No Utility</p> <ol style="list-style-type: none"> 1. Please confirm grid is lost or not; 2. Check the grid connection is good or not; 3. Check the switch between inverter and grid is on or not; 4. Seek help from us, if can not go back to normal state.
F41	Parallel system stop	<ol style="list-style-type: none"> 1. Check the hybrid inverter working status. If there's 1 pcs hybrid inverter is in OFF status, the other hybrid inverters may report F41 fault in parallel system. 2. If the fault still exists, please contact us for help.
F42	AC line low voltage	<p>Grid voltage fault</p> <ol style="list-style-type: none"> 1. Check the AC voltage is in the range of standard voltage in specification; 2. Check whether grid AC cables are firmly and correctly connected; 3. Seek help from us, if can not go back to normal state.
F47	AC over frequency	<p>Grid frequency out of range</p> <ol style="list-style-type: none"> 1. Check the frequency is in the range of specification or not; 2. Check whether AC cables are firmly and correctly connected; 3. Seek help from us, if can not go back to normal state.
F48	AC lower frequency	<p>Grid frequency out of range</p> <ol style="list-style-type: none"> 1. Check the frequency is in the range of specification or not; 2. Check whether AC cables are firmly and correctly connected; 3. Seek help from us, if can not go back to normal state.
F56	DC busbar voltage is too low	<p>Battery voltage low</p> <ol style="list-style-type: none"> 1. Check whether battery voltage is too low; 2. If the battery voltage is too low, using PV or grid to charge the battery; 3. Seek help from us, if can not go back to normal state.
F58	BMS communication fault	<ol style="list-style-type: none"> 1. it tells the communication between hybrid inverter and battery BMS disconnected when "BMS_Err-Stop" is active; 2. if don't want to see this happen, you can disable "BMS_Err-Stop" item on the LCD; 3. If the fault still exists, please contact us for help.
F63	ARC fault	<ol style="list-style-type: none"> 1. ARC fault detection is only for US market; 2. Check PV module cable connection and clear the fault; 3. Seek help from us, if can not go back to normal state.
F64	Heat sink high temperature failure	<p>Heat sink temperature is too high</p> <ol style="list-style-type: none"> 1. Check whether the work environment temperature is too high; 2. Turn off the inverter for 10mins and restart; 3. Seek help from us, if can not go back to normal state.

Chart 7-1 Fault information

Under the guidance of our company, customers return our products so that our company can provide service of maintenance or replacement of products of the same value. Customers need to pay the necessary freight and other related costs. Any replacement or repair of the product will cover the remaining warranty period of the product. If any part of the product or product is replaced by the company itself during the warranty period, all rights and interests of the replacement product or component belong to the company.

Factory warranty does not include damage due to the following reasons:

- Damage during transportation of equipment ;
- Damage caused by incorrect installation or commissioning ;
- Damage caused by failure to comply with operation instructions, installation instructions or maintenance instructions ;
- Damage caused by attempts to modify, alter or repair products ;
- Damage caused by incorrect use or operation ;
- Damage caused by insufficient ventilation of equipment ;
- Damage caused by failure to comply with applicable safety standards or regulations ;
- Damage caused by natural disasters or force majeure (e.g. floods, lightning, overvoltage, storms, fires, etc.)

In addition, normal wear or any other failure will not affect the basic operation of the product. Any external scratches, stains or natural mechanical wear does not represent a defect in the product.

8.Limitation of Liability

In addition to the product warranty described above, the state and local laws and regulations provide financial compensation for the product's power connection (including violation of implied terms and warranties). The company hereby declares that the terms and conditions of the product and the policy cannot and can only legally exclude all liability within a limited scope.

9. Datasheet

Model	AI-W5.1-3.6P1-EU	AI-W5.1-5P1-EU	AI-W5.1-6P1-EU	AI-W5.1-7.6P1-EU	AI-W5.1-8P1-EU
Battery Input Data					
Battery Type	Lead-acid or Li-Ion				
Battery Voltage Range(V)	40-60V				
Max. Charging Current(A)	90A	120A	135A	190A	190A
Max. Discharging Current(A)	90A	120A	135A	190A	190A
Charging Curve	3 Stages / Equalization				
External Temperature Sensor	yes				
Charging Strategy for Li-Ion Battery	Self-adaption to BMS				
PV String Input Data					
Max. DC Input Power(W)	4680W	6500W	7800W	9880W	10400W
PV Input Voltage(V)	370V (125V~500V)				
MPPT Range(V)	150~425V				
Full Load DC Voltage Range	300~425V		200~425V		
Start-up Voltage(V)	125V				
PV Input Current(A)	13A+13A		26A+26A		
No. of MPPT Trackers	2				
No. of Strings Per MPPT Tracker	1+1		2+2		
AC Output Data					
Rated AC Output and UPS Power(W)	3600	5000	6000	7600	8000
Max. AC Output Power(W)	3960	5500	6600	8360	8800
Peak Power(off grid)	2 times of rated power, 10 S				
AC Output Rated Current(A)	16.4/15.7A	22.7/21.7A	27.3/26.1A	34.5/33A	36.4/34.8A
Max. AC Current(A)	18/17.2A	25/23.9A	30/28.7A	38/36.3A	40/38.3A
Max. Continuous AC Passthrough(A)	35A		40A	50A	
Power Factor	0.8 leading to 0.8 lagging				
Output Frequency and Voltage	50/60Hz; L/N/PE 220/230V (single phase)				
Grid Type	Single Phase				
Total Harmonic Distortion (THD)	<3% (of nominal power)				
DC current injection	<0.5% In				
Efficiency					
Max. Efficiency	97.60%				
Euro Efficiency	96.50%				
MPPT Efficiency	>99%				
Protection					
PV Input Lightning Protection	Integrated				
Anti-islanding Protection	Integrated				
PV String Input Reverse Polarity Protection	Integrated				
Insulation Resistor Detection	Integrated				
Residual Current Monitoring Unit	Integrated				
Output Over Current Protection	Integrated				
Output Shorted Protection	Integrated				
Surge Protection	DC Type II / AC Type II				
Over Voltage Category	DC Type II / AC Type III				

Certifications and Standards	
Grid Regulation	VDE4105,IEC61727/62116,VDE0126,AS4777.2,CEI 0 21,EN50549-1, G98,G99,C10-11,UNE217002,NBR16149/NBR16150
EMC/Safety Regulation	IEC/EN 62109-1,IEC/EN 62109-2,IEC/EN 61000-6-1, IEC/EN 61000-6-2,IEC/EN 61000-6-3,IEC/EN 61000-6-4
General Data	
Operating Temperature Range(C)	-40~60 C , >45 C Derating
Cooling	Smart cooling
Noise(dB)	<30 dB
Communication with BMS	RS485; CAN
Weight(kg)	29
Cabinet size(mm)	720W×380H×254D (Excluding connectors and brackets)
Protection Degree	IP65
Installation Style	Wall-mounted
Warranty	5 years

Model	AI - W5.1					
Main Parameter						
Battery Chemistry	LiFePO4					
Battery Module Energy (kWh)	5.12					
Battery Module Voltage (V)	51.2					
Battery Module Capacity (Ah)	100					
Scalability	2	3	4	5	6	
Nominal Voltage (V)	51.2					
Operating Voltage(V)	43.2~57.6					
Energy (kWh)	10.24	15.36	20.48	25.6	30.72	
Usable Energy (kWh)	9.2	13.8	18.4	23.0	27.6	
Charge/Discharge Current (A)	Recommend	100	150	200	200	200
	Max.	180	210	240	250	250
	Peak(10s,25°C)	270	315	360	360	360
Other Parameter						
Recommend Depth of Discharge	90%					
System Dimension (W/D/H, mm)	720*255*765	720*255*1050	720*255*1335	720*255*1620	720*255*1905	
System Weight (kg)	124	177	230	283	336	
Battery Module Dimension(W/D/H, mm)	720*255*285					
Battery Module Weight (kg)	53					
Master LED Indicator	5LED(SOC:20%~100%), 3LED (working, alarming, protecting)					
IP Rating of Enclosure	IP65					
Operating Temperature	Charge: 0~55°C / Discharge: -20°C~55°C					
Storage Temperature	-20°C ~ 35°C					
Humidity	5%~95%					
Altitude	≤2000m					
Cycle Life	≥6000(25°C±2°C,0.5C/0.5C,70%EOL)					
Installation	Floor-Mounted					
Communication Port	CAN2.0, RS485					
Warranty Period	10 years					
Energy Throughput	16MWh(Battery Module @70%EOL)					
Certification	IEC62619, CE,VDE2510-10, CEI 0-21, UN38.3					

10. Appendix I

Definition of RJ45 Port Pin for BMS 485/CAN.

No.	BMS 485/CAN Pin
1	485_B
2	485_A
3	GND_485
4	CAN-H
5	CAN-L
6	GND_485
7	485_A
8	485_B

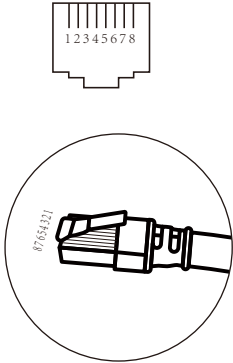

BMS 485/CAN Port

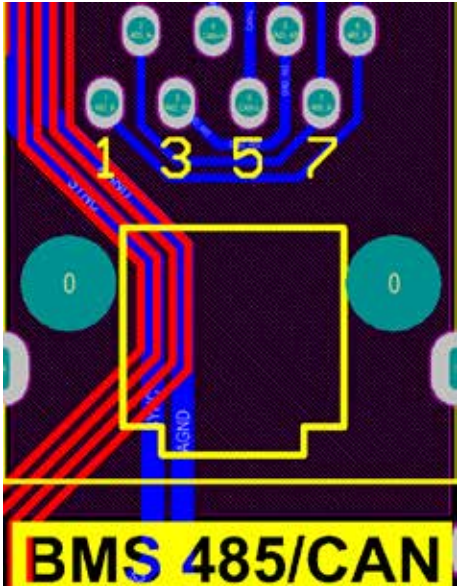

Definition of RJ45 Port Pin for RS 485.
 This port is used to communicate with energy meter.

No.	RS 485 Pin
1	--
2	--
3	--
4	485-B
5	485-A
6	--
7	--
8	--

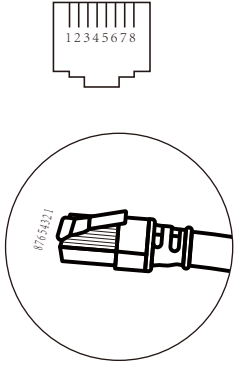

RS 485 Port

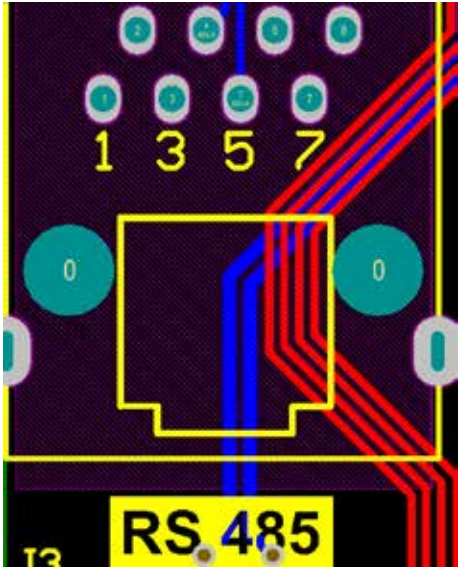

RS232

No.	WIFI/RS232
1	
2	TX
3	RX
4	
5	D-GND
6	
7	
8	
9	12Vdc

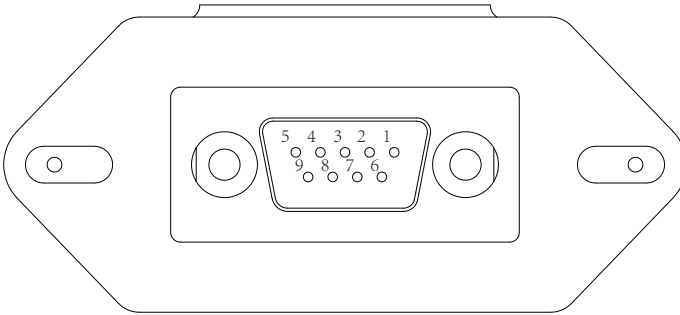

WIFI/RS232

This RS232 port is used to connect the wifi datalogger

11. Appendix II

- 1. Split Core Current Transformer (CT) dimension: (mm)
- 2. Secondary output cable length is 4m.

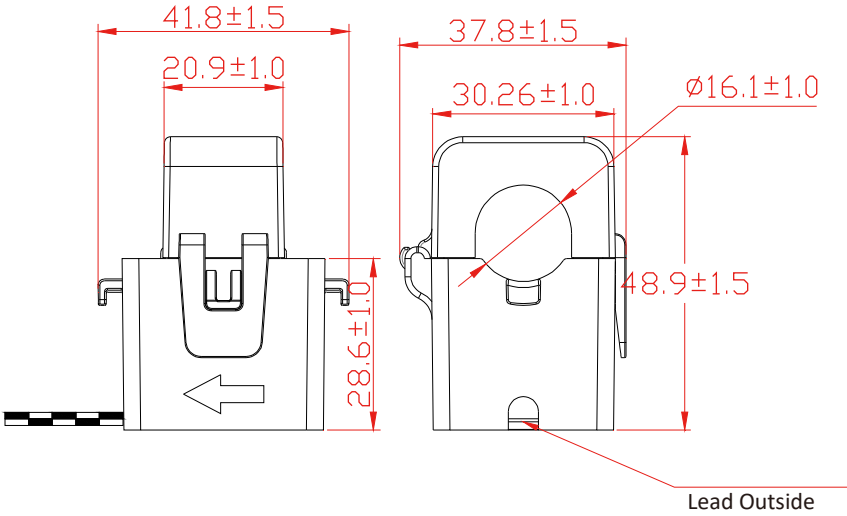

VOLTHA SRL, VENICE, ITALY
WWW.VOLTHA.NET